

***KAMATICS KARON BEARING CATALOG  
SPHERICAL, ROD END AND JOURNAL SLEEVE BEARINGS***



***KAMATICS CORPORATION***

***P. O. Box 3 (1330 Blue Hills Avenue)***

***Bloomfield, CT USA 06002***

***860-243-9704, fax 860243-7993***



***Kamatics Sales Offices***

***Please Contact Kamatics for Your Local Representative Worldwide***

***Bloomfield, CT USA***

***860-243-9704***

***fax 860-243-7993***

















***[www.kamatics.com](http://www.kamatics.com)***

# KARON Lined Spherical Bearings, Rod Ends and Journal Bearings

Please review the Kamatics KArOn Design Guide and “Spherical Bearing” section of this catalog for information about the Kamatics design approach to solving the more common problems associated with fabric lined spherical bearings, including Rod End design. Kamatics spherical bearings incorporate a unique “cathedral cavity” to securely capture the liner within the outer race in addition to the adhesive bond to provide a integral KArOn dual retention system. The KArOn liner is installed while in a liquid state and completely fills the pre-determined cavity between the ball and outer race. Ball / liner conformity is perfect.

Review the Kamatics KArOn Design Guide and “Journal Bearings” section of this catalog for items to consider when employing a self-lubricating journal bearing. Things to consider include the capability to machine the bore after installation and varying the liner thickness to suit your application.

See the Kamatics KArOn Design Guide or Table 1 of this catalog for liner choices and a description of the liners available. KArOn V is recommended for general high load bearing applications. For those applications where operating temperatures exceed +250° F (+120° C) KArOn B is recommended. Select KArOn F, M, H, VS, SP or KAtherm T87 as required for special bearing operating requirements. Contact Kamatics engineering for assistance in selecting the liner system for your application.

TABLE OF CONTENTS			Page	
			English	Metric
<b>Spherical Bearings, Karon Lined</b>				
	<b>KR-CN Series</b>	<i>MS14104 Qualified, Narrow, Chamfered Outer Race, -65° F to +325° F</i>	8	25
	<b>KR-CNG Series</b>	<i>MS14101 Qualified, Narrow, Grooved Outer Race, -65° F to +325° F</i>	9	26
	<b>KR-CW Series</b>	<i>MS14102 Qualified, Wide, Chamfered Outer Race, -65° F to +325° F</i>	10	272
	<b>KR-CWG Series</b>	<i>MS14103 Qualified, Wide, Grooved Outer Race, -65° F to +325° F</i>	11	28
	<b>KR-CN/4 Series</b>	<i>MS81820/4 Qualified, Lined Bore, Narrow, Chamfered Outer Race, -65° F to +325° F</i>	12	29
	<b>KR-CNG/1 Series</b>	<i>MS81820/1 Qualified, Lined Bore, Narrow, Grooved Outer Race, -65° F to +325° F</i>	13	30
	<b>KR-CW/2 Series</b>	<i>MS81820/2 Qualified, Lined Bore, Wide, Chamfered Outer Race, -65° F to +325° F</i>	14	31
	<b>KR-CWG/3 Series</b>	<i>MS81820/3 Qualified, Lined Bore, Wide, Grooved Outer Race, -65° F to +325° F</i>	15	32
	<b>KR-CE series</b>	<i>Extended Inner Race, High Misalignment, Chamfered Outer Race</i>	16	33
	<b>KR-CEG series</b>	<i>Extended Inner Race, High Misalignment, Grooved Outer Race</i>	17	34
	<b>KR-C Series</b>	<i>Miniature Series, Chamfered outer Race</i>	18	35
<b>Rod End Bearings</b>				
	<b>KR-F Series</b>	<i>Dimensionally Equivalent to MIL-B-81935/2, Female Rod End Body</i>	19	36
	<b>KR-M Series</b>	<i>Dimensionally Equivalent to MIL-B-81935/1, Male Rod End Body</i>	20	37
	<b>KR-FS Series</b>	<i>Miniature Series, Female Rod End Body</i>	21	38
	<b>KR-MS Series</b>	<i>Miniature Series, Male Rod End Body</i>	22	39
<b>Journal (Sleeve) Bearings</b>				
	<b>KRJ- Series</b>	<i>MIL-B-81934 Qualified, Sleeve, Non-Flanged, Lined Bore</i>	23	40
	<b>KRJ-U Series</b>	<i>MIL-B-81934 Qualified, Sleeve, Flanged, Lined Bore</i>	24	41

## Spherical Bearings

Kamatics Corporation has designed and manufactured self-lubricated spherical bearings since 1966. The original Kamatics spherical bearing was made from compacted carbon matrix liners operating against a chrome oxide coated and polished surface. This was known as a “**KAcarb**” bearing and is still in use today for applications operating at temperatures up to 1200°F degrees F (635°C). Since the early 1970’s Kamatics has manufactured spherical bearings with **KAron** self-lube liners for temperatures to 400°F (204°C) and **KAtherm** for temperatures to 600°F (315°C). Contact your Kamatics representative for further information for KAtherm and KAcarb applications.

### **Spherical Bearing Design:**

The design criterion for a KAron lined spherical bearing is similar to the criteria for a journal bearing. The major difference is that the inner race is supplied within the bearing assembly and its hardness, surface finish and corrosion resistance is normally left up to the bearing manufacturer.

**Equation 1** provides a method for calculating bearing pressures for spherical bearings and is similar to the journal bearing “projected area” approach.

Important Note: Kamatics KAron lined spherical bearings incorporate a unique “cathedral” shaped cavity between the ball OD and outer race ID. This feature “locks” the liner within the bearing overcoming the familiar problem of liner loss suffered with many fabric lined bearings. **Figure 1** shows the “cathedral” feature.

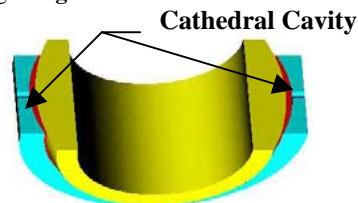

**Figure 1**

Some other important design considerations relative to the design of spherical bearings follow:

- It is imperative that the spherical surface of the ball be as hard, smooth and corrosion resistant as possible.
- There should be sufficient clamp-up torque applied to the ball faces to insure that motion takes place

between the ball OD and outer race liner unless movement within the bore is anticipated.

- For applications where it is difficult to generate enough preload on the ball faces to prevent rotation between the bore and bolt/shaft, Kamatics can supply the bearing with a KAron liner in the bore and side faces. This will eliminate damage to mating surfaces in the event that motion takes place in the bore.
- Consideration should be given to the type of installation fit between the bearing OD and housing. A press fit will reduce the operating clearance between the ball and outer race and increase the breakout torque if there is initial torque. Either condition may be acceptable for the application. The designer is cautioned to consider the consequences of the fit.
- Similar consideration should be given to the fit between the ball bore and bolt as noted above. A designer is cautioned not to use an interference fit between the ball and bolt if the ball is hardened 440C stainless steel or other materials that may be prone to stress cracking when under tensile loads.
- For those applications where the user intends to use a thermal fit technique (shrink fit) to install a KAron spherical bearing, a solution of dry ice and solvent in which to immerse the bearing is recommended.
- To assist in housing size selection, **Tables 5 and 6 of the KAron Design Guide** offer typical housing dimensions for use with KAron lined spherical bearings.

### Equation 1; Spherical bearing pressure;

$S=P/A$ , where;

- **S** = Pressure (projected area)
- **P** = Applied load (force)
- $A = D_{(ball)} \times H_{EFF}$
- $D_{(ball)}$  = Nominal ball OD
- **H** = Nominal width of the outer race
- $H_{EFF} = H$  minus “edge effects”

The “edge effects” are the possible non-load supporting liner setback allowances at each side face of the outer race. In the case of KAron lined spherical bearings, assume the setback at each side to be 0.025 inches (0.63mm) or 0.050 inches (1.27mm) total “edge effect”.

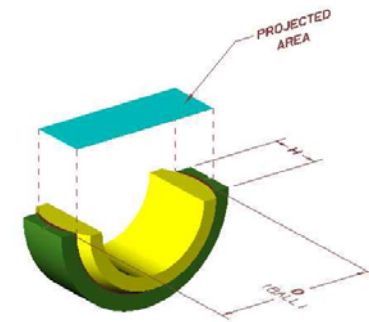

**Figure 2,**  
**(Spherical Bearing Projected Area)**

### Rod End Bearing Design:

Kamatics has over 35 years of experience manufacturing rod end assemblies. Materials range from carbon steel to high nickel alloys. Bore sizes range from 0.060 inch (1.5mm) to 3.00 inches (75mm) and larger. They are used in applications from farm equipment to space shuttles. Kamatics rod ends operate at temperatures ranging from cryogenic to 1000°F (538°F) with KAron, KAtherm, and KAcarb liner systems. This catalog offers some of the more standard sizes of rod ends available. Special sizes are produced upon request. **Figure 3** shows a typical male threaded rod end assembly.

The design of a rod end assembly requires a thorough understanding of the loads it will be subjected to. For example, if the loads are predominately compression (in the direction of the threads or shank), the banjo diameter (the hoop of metal around the bearing insert) can be thinner than if the rod end were used in tension. A tension load on the rod end body causes the hole in the body containing the bearing insert to become elongated (ovalized). Obviously, this elongation does not happen if the load is in compression (in the direction of the shank/threads) as the hole is not “stretched” in this direction.

The elongation creates a “pinching” force on the bearing insert in the 3-9 o’clock position relative to the shank. This can have two significant effects on the

assembly. First is that it tends to increase the torque required to rotate the ball. If the magnitude of the torque increase is high enough, coupled with the normal operating torque, frequent oscillation or rotation of the ball may produce unanticipated bending stresses on the rod end body and possibly lead to a fatigue failure at the banjo/shank intersection.

The second effect is relative micro motion between the housing ID and bearing OD at the 3-9 o'clock position as a consequence of the hole elongation. Frequent load reversals between tension and compression can lead to fretting between the bearing and rod end body...and eventual metal fatigue of the rod end. Classic rod end failures occur approximately 15-20 degrees below the 3-9 o'clock position.

A light interference fit between the bearing and rod end body is recommended to minimize the possibility of fretting. Kamatics manufactures spherical bearings to be installed in the rod end body with internal clearance designed to accommodate an interference fit without adding additional ball rotational torque.

The rod end body should be completely analyzed to insure that; the shank/thread size is large enough to support the loads; the banjo diameter is thick enough to react applied forces and minimize hole elongation; the fillet radius between the banjo and shank/threads is of sufficient size and with as good a surface finish as possible to minimize stress concentrations.

Kamatics is available to assist in the design of your rod end application.



**Figure 3 (male rod end assembly)**

**Journal Bearings**

Kamatics Corporation has been designing manufacturing self-lubricating journal bearings for over 30 years. The original self-lube bearing was manufactured from compact carbon sleeves shrunk-fit into metallic housings. Operating capability of this combination exceeded 1000°F (538°C) and is still in use. They are offered as “KACarb” bearings. Technological advancements have extended Kamatics products into a larger family of self-lube liner systems, all exhibiting low friction, low rates of wear, and temperatures ranging from cryogenic to over 1000°F (538°C).

The majority of journal bearings (flanged or non-flanged) are manufactured with a metallic backing. The backing can be just about any metal but it is predominately stainless steel and aluminum. However, most composite structures require that the bearing be compatible with the structure. Kamatics Corporation manufactures a large size range of KArOn lined bearings with composite backings. Carbon/epoxy and fiberglass/epoxy are the most common composite combinations used.



Composite Bearings

Kamatics has “state-of-the-art” computer controlled filament winding and braiding capabilities. Composite backed bearings in excess of 40 inches (1 meter) have been produced. Kamatics KArOn lined/composite backed bearings are qualified to MIL-B-85560. Composite bearings for operation at temperatures to 600°F (315°C) are possible with our KAtherm technology.

Kamatics also produces bearings made from solid KArOn...without any backing for those applications where space is limited. Solid KArOn bearings are

normally pressed in, or bonded to, a housing and when installed have similar load and performance capabilities of metal or composite backed KArOn bearings. A suggested approach to the design of both flanged and non-flanged KArOn self-lubricating journal bearings is offered below.

The bearing pressure distribution used in the following equations is in a simplified form. Forgoing extensive discussion on actual pressure distribution and for calculation purposes, assume the area supporting the load to be a “projected area” pressure as defined in **Equation 2.**

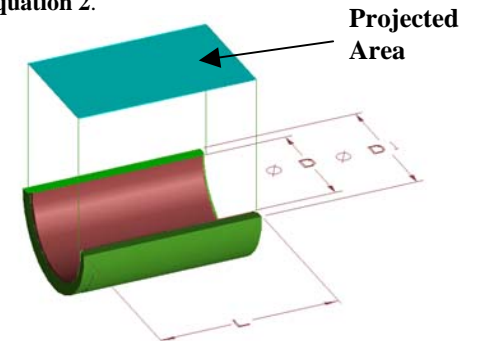

**Figure 4, (Non-flanged Journal)**

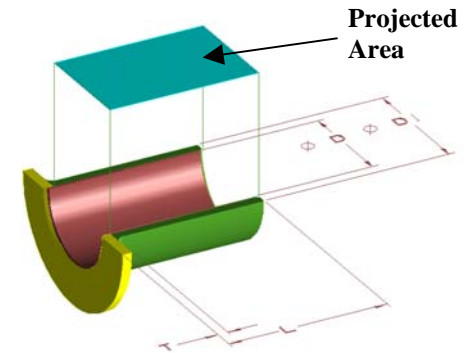

**Figure 4, (Flanged Journal)**

**Equation 2;** Journal bearing pressure;  $S=P/A$ , where;

- **S** = Pressure (projected area)
- **P** = Applied load (force)
- **A** =  $D \times L_{EFF}$
- **D** = Nominal journal ID

- **L** = Nominal length of the journal (including the flange if there is one)
  - **L<sub>EFF</sub>** = **L** minus “edge effects”
- The “edge effects” are the non-load supporting chamfers and the area under the flange, in the case of flanged journals. The “Projected Area” concept defined is widely used in the bearing industry and most published load ratings are based on this concept.

Sizing of the journal bore is based upon a combination of load, shear and tensile allowables of the bolt/pin material plus any bending under load. The bearing stress on the bearing should be checked once the bolt/pin diameter has been established.

It is important to be as accurate as possible when determining forces and both normal operating and maximum forces are required. For instance, supplying and calculating size based only on the maximum force coupled with an operation or flight spectrum may cause the bearing to be larger than necessary or the amount of calculated wear to be unrealistically high. (Obviously, the bolt/pin has to be selected based on maximum loading among other things.) If the operating time at maximum load is relatively low and cycles are few, it may be overlooked for the initial sizing. This is assuming the loads are within the liner materials capability (below static limit load value). Once initially sized, the amount of wear attributed to the operating extremes can be added to the amount of wear attributed to the normal operating conditions. All movement under load has some contribution to the total wear.

The length of the journal bearing should be kept to a length-to-diameter (L/D) ratio of less than 1.5 to keep both pin bending and edge loading to a minimum. Edge loading can lead to more than anticipated wear. Larger L/D ratios can be designed but only after careful consideration to pin bending is given. Bell-mouths (shallow tapers) machined into the bore will minimize edge loading due to large L/D ratios.

Things to consider in the design of a KAron lined self-lube journal bearing:

- **KAron liner material is machinable** using conventional turning, reaming or honing procedures. Appendix A of the Kamatics KAron Design guide explains these techniques. Bearings can be supplied with thicker liner material to allow for final machining of the ID after installation.

- Consideration should be given to the type of installation fit between the bearing OD and housing. A press fit will reduce the operating clearance between the bore and mating shaft, and if not addressed, may create an interference with the shaft. Tables 2 & 3 of the KAron Design Guide offer housing dimensions for use with KAron journal bearings.
- As in the case of many journal bearing applications, the bearing manufacturer supplies only one half of the bearing system. The end user supplies the other half of the bearing system in the form of a bolt, sleeve, pin or similar.
- As noted, the user supplies the mating part and the installation of this mating part must be carefully controlled. The shaft must be accurately aligned to minimize liner damage during insertion into the bearing. It should have a smooth chamfer or radius on the end that enters the bearing. Fortunately, Kamatics self-lube liners have a significant advantage over fabric self-lube bearings in that in the event of localized damage during shaft installation, the damage remains local. There are no interconnecting fibers or weave that will allow the damage to progress and propagate under load until loss of liner or jamming of the shaft has occurred in the bore.
- It is important to select the most corrosion resistant and hardest material with the smoothest surface finish possible *for the application under consideration*. Consider the use of hard chrome plate to further enhance the shaft finish and hardness.
- The selection of mating materials can be a difficult decision and in order not to “over-design”, the amount of wear and the type and number of expected operating cycles should be known.

Table 1 lists potential trade-off relative to life with various mating shaft hardnesses and surface finishes. Table 1 displays general “trend” type of information and should not be taken as an absolute value. Kamatics engineering is available for guidance if necessary.

**TABLE 1**

Mating Bearing Surface	
Surface Finish	
Roughness - $\mu\text{in.}$	Life Factor
4-10 (.025-.25 $\mu\text{m}$ )	1.00
16 (0.4 $\mu\text{m}$ )	.75
32 (0.8 $\mu\text{m}$ )	.40

Surface Hardness	
Hardness Rc	Life Factor
50+	1.00
40	.60
30	.40

**Catalog Load Rating Definitions:** See SAE AS81820 and AS81934 for a more complete explanation.

**Radial Dynamic Load**

The radial dynamic load capacities noted in this catalog are based on specification SAE AS81820. These requirements are configured for approximately .0045 inches (0.11 mm) of maximum liner wear after 25000 cycles of inner ring oscillating at  $\pm 25^\circ$  ( $50^\circ$  included angle) and at 10 cpm. The “-4” sizes are slightly less, .0037 (0.094mm) inches for the narrow series and .0039 inches (0.10mm) for the wide series.

**Radial Static Limit Load**

The radial static limit load rating is the maximum radial load that will result in a permanent set in the bearing no greater than .003 inches (0.076mm) after the load is applied for three minutes.

**Axial Static Limit Load Rating**

The axial static limit load rating is the maximum axial (thrust) load that will result in a permanent set in the bearing no greater than .005 inches (0.127mm) after the load is applied for three minutes.

**Ultimate Static Load Rating**

The ultimate radial and axial load rating equals 1.5 times the radial and axial static limit loads listed. At loads equal to this magnitude, no race or ball fracture shall occur, nor will the ball become dislodged from the race.

**Fatigue Load (Rod Ends)**

The fatigue load capacity listed for the rod ends in this catalog are based on the requirements of SAE AS81935. The ratings listed will endure a minimum of 50,000 load reversals.

**TABLE 2**

Liner	Approximate Physical Properties	Characteristics	Typical Applications
<b>KAron B</b> High Load	Density – 1.51 gm/cc Hardness Rockwell M95 Thickness Range .005 - .060" (.127 – 1.5 mm)	Dynamic operating Pressures to 50,000 psi (345 mPa). Velocities to 3 fpm (1 M/min.) Temp Range –100° to 400° F (-73° to >205°C) SAE AS81820 & SAE AS81934 Qualified	Aircraft controls, landing gears etc. Highly loaded linkages. Jet engine controls. Other high loaded demanding, maintenance free applications.
<b>KAron V</b> High Load / Low Friction	Density – 1.36 gm/cc Hardness Rockwell M85 Thickness Range .005 - .060" (.127 – 1.5 mm)	Dynamic operating Pressures to 40,000 psi (276 mPa). Velocities to 10 fpm (3 M/min.) Temp Range –100° to 300° F (-73° to 150°C) Mil-B-8943 Qualified	Track rollers. Cam followers. Marine/naval applications. Aircraft shock struts. Other high loaded, low friction applications.
<b>KAron F</b> Low Friction	Density – 1.36 gm/cc Hardness Rockwell M85 Thickness Range .003" – min. (.076 mm min.)	Rubbing surface is a predominately PTFE enriched outer surface, providing low coefficient of friction at low loads and at low temperatures. The general operating parameters are the same as KAron V. A minimum thickness liner of .003" (.076 mm) can be obtained.	Spherical bearings Track rollers. Cam followers Other moderately high loaded, low friction applications
<b>KAron VS</b> Low Friction	Density – 1.56 gm/cc Hardness Rockwell 15X 88 Thickness Range .005 - .060" (.127 – 1.5 mm)	Dynamic operating pressures up to 15,000 psi (103mPa), excellent low temperature friction capabilities. Temp Range –100° to 300° F (-73° to 150°C)	Spherical bearings Track rollers. Cam followers Other moderate loaded, low friction applications
<b>KAron RP</b> Low Friction	Density – 1.60 gm/cc Hardness Rockwell M80 Thickness Range .005 - .060" (.127 – 1.5 mm)	Dynamic operating Pressures to 30,000 psi (205 mPa). Velocities to 10 fpm (3 M/min.) Temp Range –100° to 250° F (-73° to 120°C) Mil-B-8943 Qualified	Landing gear shock struts and other moderate load, relatively high speed, low friction applications.
<b>KAron M</b> Ductile	Density – 1.36 gm/cc Hardness Rockwell M80 Thickness Range .005 - .060" (.127 – 1.5 mm)	Dynamic operating Pressures to 35,000 psi (240 mPa). Velocities to 10 fpm (3 M/min.) Temp Range –100° to 250° F (-73° to 120°C) Mil-B-8943 Qualified	Landing gear shock struts. Other applications requiring low friction and low rates of wear along with a degree of ductility to accommodate system deflections.
<b>KAron SP</b> Ductile	Density – 1.44 gm/cc Hardness Rockwell 15X 77 Thickness Range .005 - .060" (.127 – 1.5 mm)	Dynamic operating pressures up to 25,000 psi (145mPa), excellent low temperature friction capabilities. Temp Range –100° to 250° F (-73° to 121°C) Designed for Mil-B-8943	Landing gear shock struts. Other applications requiring low friction and low rates of wear along with a degree of ductility to accommodate system deflections.
<b>KAron H</b> High Speed	Density – 1.85 gm/cc Hardness Rockwell M90 Thickness Range .005 - .060" (.127 – 1.5 mm)	Dynamic operating Pressures to 20,000 psi (140 mPa). Velocities to 30 fpm (9 M/min.) Temp Range –100° to 250° F (-73° to 120°C) Designed for SAE AS81819	Helicopter rotor controls. Other high speed, moderate load low friction applications.
<b>KAtherm T87</b> High Speed / High Temperature <b>500°F (260°C)</b>	Density – 1.37 gm/cc Hardness Rockwell M80/90 Thickness Range .005 - .030" (.127 – .75 mm)	Dynamic operating Pressures to 20,000 psi (140 mPa). Velocities to 30 fpm (9 M/min.) Temp Range –100° to 500° F (-73° to 260°C) Designed for SAE AS81819	Formulated for high temperature applications to 500°F (260°C) such as VG bushings, engine linkages, thrust reverser, cam followers, track rollers and helicopter rotor control bearing
<b>KAtherm T88</b> High Speed / High Temperature <b>600°F (316°C)</b>	Density – 1.30 gm/cc Hardness Rockwell M80/90 Thickness Range .005 - .030" (.127 – .75 mm)	Dynamic operating Pressures to 10,000 psi (70 mPa). Velocities to 30 fpm (9 M/min.) Temp Range –100° to 600° F (-73° to 316°C)	Formulated for high temperature applications to 600°F (316°C) such as VG bushings, engine linkages, thrust reverser, cam followers, track rollers and helicopter rotor control bearing

# KARON Lined Spherical Bearings



**KR-CN Series – Narrow, Chamfered Outer Race**  
**-65° F to +325° F**  
**KR3 to KR16 Qualified to SAE AS81820 with Karon B Liner**

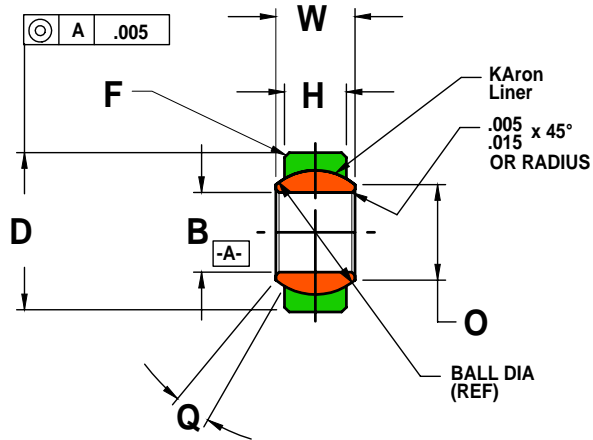

Part Number Example:  
**KR 6 - CN B P W K I Y**

**KR** = Basic Karon Spherical Bearing Prefix  
**6** = .3750 ID (ID in 1/16 increments)  
**CN** = Narrow Chamfered Outer Race  
**B** = Karon B liner (See Table 2 for liner options)  
**P** = Cadmium Plated OD per QQ-P-416 Option  
**W** = Chrome Plated Ball OD Option  
**K** = Low Breakaway Torque Option  
**T** = .010 Oversize OD Option  
**Y** = PH13-8Mo Ball option (440C no letter)

See KR-CN/4 Series for Lined Bore

Bearing Size	Nominal Bore	T	U
		.010 OD Oversize +.0000 -.0005	.020 OD Oversize +.0000 -.0005
-3	.1900	.5725	.5825
-4	.2500	.6662	.6762
-5,5A	.3125	.7600	.7700
-6	.3750	.8225	.8325
-7	.4375	.9162	.9262
-8	.5000	1.0100	1.0200
-9	.5625	1.1037	1.1137
-10	.6250	1.1975	1.2075
-12	.7500	1.4475	1.4575
-14	.8750	1.5725	1.5825
-16	1.0000	1.7600	1.7700
-20	1.2500	2.0100	2.0200

AS14104/ MS14104 (Ref)	B	D	W	H	O	F	Q°					
BEARING NUMBERS	BORE DIA	OUTSIDE DIA	BALL WIDTH	RACE WIDTH	SHOULDER DIA (MIN)	BALL DIA (REF)	CHAMFER X 45°	RADIAL DYNAMIC LOAD RATING (LBS) See Note 1	APPROX. MISALIGNMENT (°)	RADIAL STATIC LIMIT LOAD (LBS) See Note 1	AXIAL STATIC LIMIT LOAD (LBS) See Note 1	APPROX WEIGHT (LBS)
	+.0000 -.0005	+.0000 -.0005	+.000 -.002	+.005 -.005								
KR3-CN	.1900	.5625	.281	.218	.293	.406		1500	10	3975	150	.02
KR4-CN	.2500	.6562	.343	.250	.364	.500	.010/.020	3320	10	6040	430	.02
KR5-CN	.3125	.7500	.375	.281	.419	.562		5460	10	8750	700	.03
KR6-CN	.3750	.8125	.406	.312	.475	.625		6600	9	10540	1100	.04
KR7-CN	.4375	.9062	.437	.343	.530	.687		8050	8	13200	1400	.05
KR8-CN	.5000	1.0000	.500	.390	.600	.781	.020/.030	10400	8	17900	2100	.07
KR9-CN	.5625	1.0937	.562	.437	.670	.875		13000	8	23200	3680	.09
KR10-CN	.6250	1.1875	.625	.500	.739	.968		16450	8	30500	4720	.12
KR12-CN	.7500	1.4375	.750	.593	.920	1.187		23600	8	46400	6750	.21
KR14-CN	.8750	1.5625	.875	.703	.980	1.312	.030/.040	30250	8	62200	9350	.27
KR16-CN	1.000	1.7500	1.000	.797	1.118	1.500		38000	9	82200	12160	.39
KR20-CN	1.2500	2.0000	1.093	.942	1.406	1.781		52100	6	108000	15500	.53

Bearing Size	No-Load Rotational Breakaway Torque In.-lbs.		Bearing Clearances "K" Type Only	
	Standard	"K" Type	Radial (Max.) (inch)	Axial (Max.) (inch)
3 and 4	0.25 to 5.0	0 to 0.5	0.0007	0.0028
5 thru 12	0.25 to 8.0	0 to 1.0	0.0007	0.0028
14 thru 20	0.25 to 12	0 to 2.0	0.0010	0.0040

**Bearing Materials:**

**Liner** = See Table 2 for liner options  
**Outer Race** = 17-4PH (AMS5643) H1150 Cond.  
**Ball** = 440C (AMS5630) HRC 55/62 or PH13-8Mo (AMS5629) H1000 Cond.  
 Passivate PH13-8Mo per QQ-P-35,  
 Chrome option per QQ-C-320 Class 2 (.0002-.0005 thick).

**Note 1:** Load Ratings Shown are with Karon B Liner System

# KARON Lined Spherical Bearings

**KR-CNG Series – Narrow, Grooved Outer Race**  
**-65° F to +325° F**  
**KR3 to KR16 Qualified to SAE AS81820 with Karon B Liner**

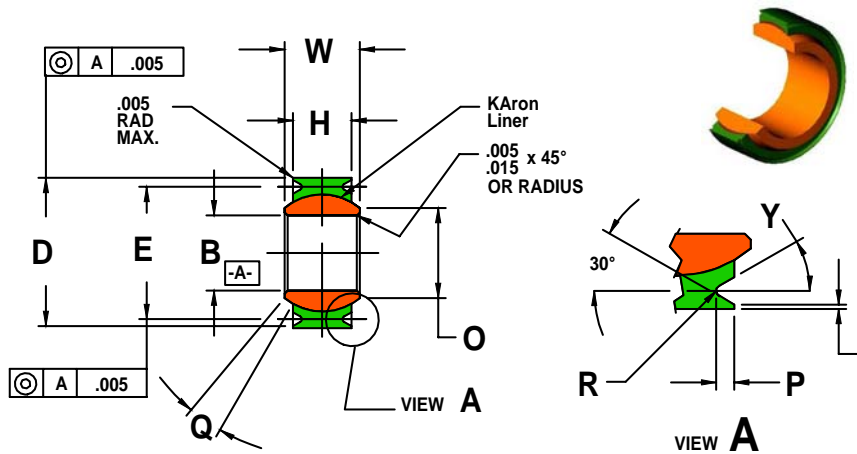

Part Number Example:  
**KR 6 - CN G B P W K T Y**

**KR** = Karon Spherical Bearing Prefix  
**6** = .3750 ID (ID in 1/16 increments)  
**CN** = Narrow Outer Race  
**G** = Grooved Outer Race  
**B** = Karon B liner (See Table 2 for liner options)  
**P** = Cadmium Plated OD per QQ-P-416 Option  
**W** = Chrome Plated Ball OD Option  
**K** = Low Breakaway Torque Option  
**T** = .010 Oversize OD Option  
**Y** = PH13-8Mo Ball option (440C no letter)

Bearing Size	Nominal Bore	T	U
		.010 OD Oversize +.0000 -.0005	.020 OD Oversize +.0000 -.0005
-3	.1900	.5725	.5825
-4	.2500	.6662	.6762
-5,5A	.3125	.7600	.7700
-6	.3750	.8225	.8325
-7	.4375	.9162	.9262
-8	.5000	1.0100	1.0200
-9	.5625	1.1037	1.1137
-10	.6250	1.1975	1.2075
-12	.7500	1.4475	1.4575
-14	.8750	1.5725	1.5825
-16	1.0000	1.7600	1.7700
-20	1.2500	2.0100	2.0200

See KR-CNG/1 Series for Lined Bore

AS14101/ MS14101 (Ref)	B	D	W	H	O	E	Q°					
BEARING NUMBERS	BORE DIA	OUTSIDE DIA	BALL WIDTH	RACE WIDTH	SHOULDER DIA (MIN)	BALL DIA (REF)	GROOVE DIA +.000 -.008	RADIAL DYNAMIC LOAD RATING (LBS) See Note 1	APPROX. MISALIGNMENT (°)	RADIAL STATIC LIMIT LOAD (LBS) See Note 1	AXIAL STATIC LIMIT LOAD (LBS) See Note 1	APPROX WEIGHT (LBS)
	+.0000 -.0005	+.0000 -.0005	+.000 -.002	+.005 -.005								
KR3-CNG	.1900	.5625	.281	.218	.293	.406	.500	1500	10	3975	150	.02
KR4-CNG	.2500	.6562	.343	.250	.364	.500	.594	3320	10	6040	430	.02
KR5-CNG	.3125	.7500	.375	.281	.419	.562	.650	5460	10	8750	700	.03
KR5A-CNG	.3125	.7500	.375	.281	.419	.562	.660	5460	10	8750	700	.03
KR6-CNG	.3750	.8125	.406	.312	.475	.625	.712	6600	9	10540	1100	.04
KR7-CNG	.4375	.9062	.437	.343	.530	.687	.806	8050	8	13200	1400	.05
KR8-CNG	.5000	1.0000	.500	.390	.600	.781	.876	10400	8	17900	2100	.07
KR9-CNG	.5625	1.0937	.562	.437	.670	.875	.970	13000	8	23200	3680	.09
KR10-CNG	.6250	1.1875	.625	.500	.739	.968	1.063	16450	8	30500	4720	.12
KR12-CNG	.7500	1.4375	.750	.593	.920	1.187	1.313	23600	8	46400	6750	.21
KR14-CNG	.8750	1.5625	.875	.703	.980	1.312	1.438	30250	8	62200	9350	.27
KR16-CNG	1.000	1.7500	1.000	.797	1.118	1.500	1.626	38000	9	82200	12160	.39
KR20-CNG	1.2500	2.0000	1.093	.942	1.406	1.781	1.876	52100	6	108000	15500	.53

Bearing Size	No-Load Rotational Breakaway Torque In.-lbs.		Bearing Clearances "K" Type Only	
	Standard	"K" Type	Radial (Max.) (Inch)	Axial (Max) (Inch)
3 and 4	0.25 to 5.0	0 to 0.5	0.0007	0.0028
5 thru 12	0.25 to 8.0	0 to 1.0	0.0007	0.0028
14 thru 20	0.25 to 12	0 to 2.0	0.0010	0.0040

**Bearing Materials:**  
**Liner** = See Table 2 for liner options  
**Outer Race** = 17-4PH (AMS5643) H1150 Cond.  
**Ball** = 440C (AMS5630) HRC 55/62 or PH13-8Mo (AMS5629) H1000 Cond.  
 Passivate PH13-8Mo per QQ-P-35,  
 Chrome option per QQ-C-320 Class 2 (.0002-.0005 thick).  
**Note 1: Load Ratings Shown are with Karon B Liner**

Bearing Size	P (inch)	R (inch)	S (inch)	Y°
	+.000 -.010	+.000 -.005	Ref.	
3 and 4	.025	.010	.010	20/30
5A	.035	.010	.010	20/30
5 thru 7	.035	.017	.020	30
8 thru 20	.055	.017	.020	30

# KARON Lined Spherical Bearings

**KR-CW Series – Wide, Chamfered Outer Race**  
**-65° F to +325° F**  
**KR3 to KR16 Qualified to SAE AS81820 with Karon B Liner**

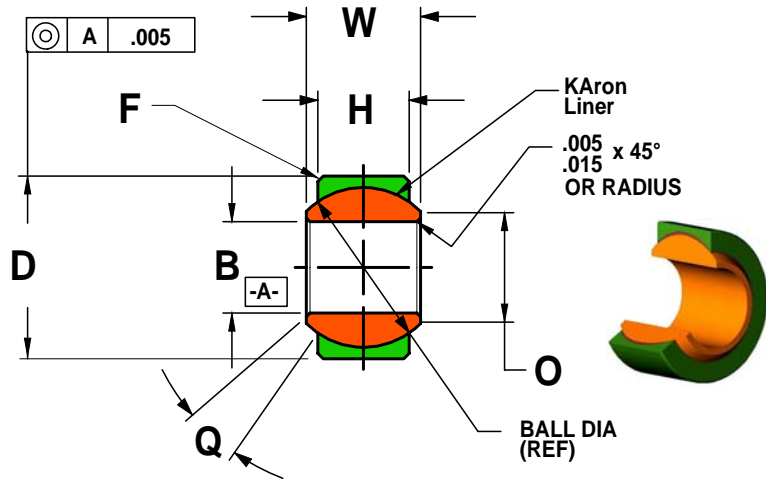

Part Number Example:  
**KR 6 - CW B P W K T Y**

**KR** = Karon Spherical Bearing Prefix  
**6** = .3750 ID (ID in 1/16 increments)  
**CW** = Chamfered Wide Outer Race  
**B** = Karon B liner (See Table 2 for liner options)  
**P** = Cadmium Plated OD per QQ-P-416 Option  
**W** = Chrome Plated Ball OD Option  
**K** = Low Breakaway Torque Option  
**T** = .010 Oversize OD Option  
**Y** = PH13-8Mo Ball option (440C no letter)

See KR-CW/2 for Lined Bore

Bearing Size	Nominal Bore	T	U
		.010 OD Oversize +.0000 -.0005	.020 OD Oversize +.0000 -.0005
-3	.1900	.6350	.6450
-4	.2500	.6350	.6450
-5	.3125	.6975	.7075
-6	.3750	.8225	.8325
-7	.4375	.9475	.9575
-8	.5000	1.0100	1.0200
-9	.5625	1.1350	1.1450
-10	.6250	1.1975	1.2075
-12	.7500	1.3850	1.3950
-14	.8750	1.6350	1.6450
-16	1.0000	2.1350	2.1450
-20	1.2500	2.3850	2.3950

AS14102/ MS14102 (Ref)	B	D	W	H	O	F	Q°					
BEARING NUMBERS	BORE DIA	OUTSIDE DIA	BALL WIDTH	RACE WIDTH	SHOULDER DIA (MIN)	BALL DIA (REF)	CHAMFER X 45°	RADIAL DYNAMIC LOAD RATING (LBS) See Note 1	APPROX. MISALIGNMENT (°)	RADIAL STATIC LIMIT LOAD (LBS) See Note 1	AXIAL STATIC LIMIT LOAD (LBS) See Note 1	APPROX WEIGHT (LBS)
	+.0000 -.0005	+.0000 -.0005	+.000 -.002	+.005 -.005								
KR3-CW	.1900	.6250	.437	.327	.300	.531		4900	15	2500	1770	.03
KR4-CW	.2500	.6250	.437	.327	.300	.531	.015/.025	4900	15	5500	1770	.03
KR5-CW	.3125	.6875	.437	.317	.360	.562		6050	14	9400	1640	.04
KR6-CW	.3750	.8125	.500	.406	.466	.687		8310	8	13700	2630	.06
KR7-CW	.4375	.9375	.562	.442	.537	.781		11750	10	20700	3650	.08
KR8-CW	.5000	1.0000	.625	.505	.607	.875	.020/.030	14950	9	21400	4970	.10
KR9-CW	.5625	1.1250	.687	.536	.721	1.000		18100	10	26600	5370	.14
KR10-CW	.6250	1.1875	.750	.567	.747	1.062		20250	12	29000	6130	.16
KR12-CW	.7500	1.3750	.875	.630	.845	1.218		26200	13	37000	7730	.24
KR14-CW	.8750	1.6250	.875	.755	.995	1.375	.030/.040	33600	6	65200	10800	.35
KR16-CW	1.000	2.1250	1.375	1.005	1.269	1.875		56250	12	104000	19300	.97
KR20-CW	1.2500	2.3750	1.500	1.130	1.460	2.093		65900	14	153000	21400	1.10

Bearing Size	No-Load Rotational Breakaway Torque In.-lbs.		Bearing Clearances "K" Type Only	
	Standard	"K" Type	Radial (Max.) (Inch)	Axial (Max) (Inch)
3 and 4	0.25 to 5.0	0 to 0.5	0.0007	0.0028
5 thru 12	0.25 to 8.0	0 to 1.0	0.0007	0.0028
14 thru 20	0.25 to 12	0 to 2.0	0.0010	0.0040

### Bearing Materials:

**Liner** = See Table 2 for liner options  
**Outer Race** = 17-4PH (AMS5643) H1150 Cond.  
**Ball** = 440C (AMS5630) HRC 55/62 or PH13-8Mo (AMS5629) H1000 Cond.  
 Passivate PH13-8Mo per QQ-P-35,  
 Chrome option per QQ-C-320 Class 2 (.0002-.0005 thick).

**Note 1:** Load Ratings Shown are with Karon B Liner System

# KARON Lined Spherical Bearings

**KR-CWG Series – Wide, Grooved Outer Race**  
**-65°F to +325°F**  
**KR3 to KR16 Qualified to SAE AS81820 with Karon B Liner**

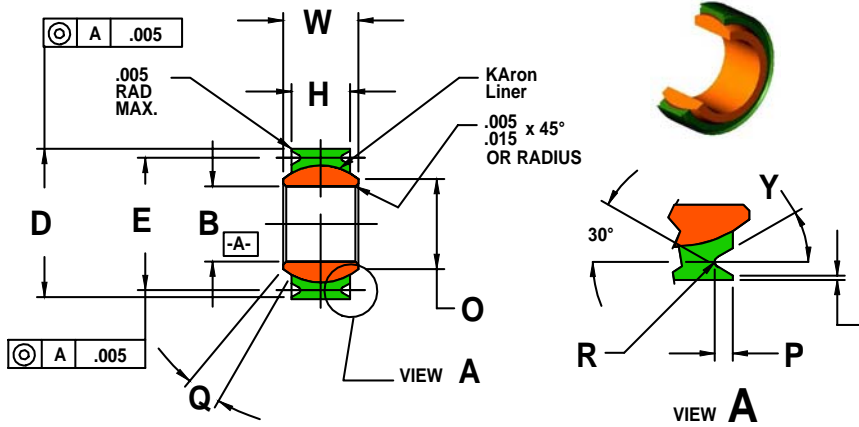

Part Number Example:  
**KR 6 - CW G B P W K T Y**

**KR** = Karon Spherical Bearing Prefix  
**6** = .3750 ID (ID in 1/16 increments)  
**CW** = Chamfered Wide Outer Race  
**G** = Grooved Outer Race  
**B** = Karon B liner (See Table 2 for liner options)  
**P** = Cadmium Plated OD per QQ-P-416 Option  
**W** = Chrome Plated Ball OD Option  
**K** = Low Breakaway Torque Option  
**T** = .010 Oversize OD Option  
**Y** = PH13-8Mo Ball option (440C no letter)

See KR-CWG/3 for Lined Bore

Bearing Size	Nominal Bore	T	U
		.010 OD Oversize +.0000 -.0005	.020 OD Oversize +.0000 -.0005
-3	.1900	.6350	.6450
-4	.2500	.6350	.6450
-5	.3125	.6975	.7075
-6	.3750	.8225	.8325
-7	.4375	.9475	.9575
-7A	.4375	.9162	.9262
-8	.5000	1.0100	1.0200
-9	.5625	1.1350	1.1450
-10	.6250	1.1975	1.2075
-12	.7500	1.3850	1.3975
-14	.8750	1.6350	1.6450
-16	1.0000	2.1350	2.1450
-20	1.2500	2.3850	2.3975

AS14103/ MS14103 (Ref)	B	D	W	H	O		E		Q°			
BEARING NUMBERS	BORE DIA	OUTSIDE DIA	BALL WIDTH	RACE WIDTH	SHOULDER DIA (MIN)	BALL DIA (REF)	GROOVE DIA +.000 -.008	RADIAL DYNAMIC LOAD RATING (LBS)	APPROX. MISALIGNMENT (°)	RADIAL STATIC LIMIT LOAD (LBS)	AXIAL STATIC LIMIT LOAD (LBS)	APPROX WEIGHT (LBS)
	+.0000 -.0005	+.0000 -.0005	+.000 -.002	+.005 -.005								
KR3-CWG	.1900	.6250	.437	.327	.300	.531	.563	4900	15	2500	1770	.03
KR4-CWG	.2500	.6250	.437	.327	.300	.531	.563	4900	15	5500	1770	.03
KR5-CWG	.3125	.6875	.437	.317	.360	.562	.622	6050	14	9400	1640	.04
KR6-CWG	.3750	.8125	.500	.406	.466	.687	.712	8310	8	13700	2630	.06
KR7-CWG	.4375	.9375	.562	.442	.537	.781	.837	11750	10	20700	3650	.08
KR7A-CWG	.4375	.9062	.562	.442	.537	.781	.806	11750	10	20700	3650	.08
KR8-CWG	.5000	1.0000	.625	.505	.607	.875	.900	14950	9	21400	4970	.10
KR9-CWG	.5625	1.1250	.687	.536	.721	1.000	1.025	18100	10	26600	5370	.14
KR10-CWG	.6250	1.1875	.750	.567	.747	1.062	1.087	20250	12	29000	6130	.16
KR12-CWG	.7500	1.3750	.875	.630	.845	1.218	1.251	26200	13	37000	7730	.24
KR14-CWG	.8750	1.6250	.875	.755	.995	1.375	1.501	33600	6	65200	10800	.35
KR16-CWG	1.000	2.1250	1.375	1.005	1.269	1.875	2.001	56250	12	104000	19300	.97
KR20-CWG	1.2500	2.3750	1.500	1.130	1.460	2.093	2.251	65900	14	153000	21400	1.10

Bearing Size	No-Load Rotational Breakaway Torque In.-lbs.		Bearing Clearances "K" Type Only	
	Standard	"K" Type	Radial (Max.) (Inch)	Axial (Max) (Inch)
3 and 4	0.25 to 5.0	0 to 0.5	0.0007	0.0028
5 thru 12	0.25 to 8.0	0 to 1.0	0.0007	0.0028
14 thru 20	0.25 to 12	0 to 2.0	0.0010	0.0040

Bearing Size	P (in)	R (in)	S (in)	Y°
	+.000 -.010	+.000 -.007	Ref.	
3 and 5	.025	.012	.010	20/3
6 thru 10	.035	.017	.020	30
10 thru 20	.055	.017	.020	30

**Bearing Materials:**

**Liner** = See Table 2 for liner options  
**Outer Race** = 17-4PH (AMS5643) H1150 Cond.  
**Ball** = 440C (AMS5630) HRC 55/62 or PH13-8Mo (AMS5629) H1000 Cond. Passivate PH13-8Mo per QQ-P-35, Chrome option per QQ-C-320 Class 2 (.0002-.0005 thick).

**Note 1:** Load Ratings Shown are with Karon B Liner System

# KARON Lined Spherical Bearings

**KR-CN/4 Series – Narrow, Chamfered Outer Race**  
**Lined Bore, -65° F to +325° F**  
**KR4 to KR16 Qualified to SAE AS81820 with Karon B Liner**

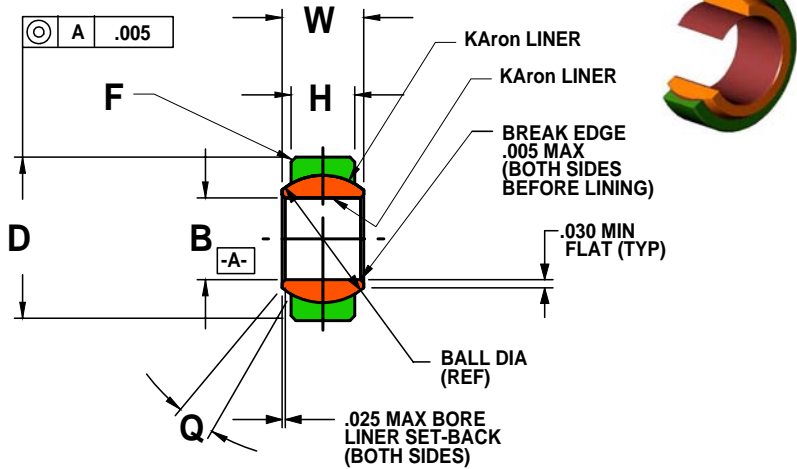

Part Number Example:  
**KR 6- CN /4 B P W K T Y**

**KR** = Karon Spherical Bearing Prefix  
**6** = .3750 ID (ID in 1/16 increments)  
**CN** = Narrow Outer Race  
**/4** = Karon Lined Bore (ID)  
**B** = Karon B liner (See Table 2 for liner options)  
**P** = Cadmium Plated OD per QQ-P-416 Option  
**W** = Chrome Plated Ball OD Option  
**K** = Low Breakaway Torque Option  
**T** = .010 Oversize OD Option  
**Y** = PH13-8Mo Ball option (440C no letter)

Bearing Size	Maximum Bore	T	U
		.010 OD Oversize +.0000 -.0005	.020 OD Oversize +.0000 -.0005
-3	.1910	.5725	.5825
-4	.2510	.6662	.6762
-5	.3135	.7600	.7700
-6	.3760	.8225	.8325
-7	.4385	.9162	.9262
-8	.5010	1.0100	1.0200
-9	.5635	1.1037	1.1137
-10	.6260	1.1975	1.2075
-12	.7510	1.4475	1.4575
-14	.8760	1.5725	1.5825
-16	1.0010	1.7600	1.7700
-20	1.2510	2.0100	2.0200

AS81820/4 M81820/4 (Ref)	B	D	W	H		F		Q°			
BEARING NUMBERS	BORE DIA	OUTSIDE DIA	BALL WIDTH	RACE WIDTH	BALL DIA (REF)	CHAMFER X 45°	RADIAL DYNAMIC LOAD RATING (LBS) See Note 1	APPROX. MISALIGNMENT (°)	RADIAL STATIC LIMIT LOAD (LBS) See Note 1	AXIAL STATIC LIMIT LOAD (LBS) See Note 1	APPROX WEIGHT (LBS)
	+0.0000 -0.0010	+0.0000 -0.0005	+0.000 -0.002	+0.005 -0.005							
KR3-CN/4	.1910	.5625	.281	.218	.406		1500	10	3975	150	.02
KR4-CN/4	.2510	.6562	.343	.250	.500	.010/.020	2650	10	5550	430	.02
KR5-CN/4	.3135	.7500	.375	.281	.562		3700	10	7700	700	.03
KR6-CN/4	.3760	.8125	.406	.312	.625		4900	9	10200	1100	.04
KR7-CN/4	.4385	.9062	.437	.343	.687		6700	8	12950	1400	.05
KR8-CN/4	.5010	1.0000	.500	.390	.781	.020/.030	8250	8	17250	2100	.07
KR9-CN/4	.5635	1.0937	.562	.437	.875		10500	8	22150	3680	.09
KR10-CN/4	.6260	1.1875	.625	.500	.968		13250	8	27700	4720	.12
KR12-CN/4	.7510	1.4375	.750	.593	1.187		19400	8	40500	6750	.21
KR14-CN/4	.8760	1.5625	.875	.703	1.312	.030/.040	26750	8	55950	9350	.27
KR16-CN/4	1.0010	1.7500	1.000	.797	1.500		35250	9	73800	12160	.39
KR20-CN/4	1.2510	2.0000	1.093	.942	1.781		48250	6	108000	15500	.53

Bearing Size	No-Load Rotational Breakaway Torque In.-lbs.		Bearing Clearances "K" Type Only	
	Standard	"K" Type	Radial (Max.) (inch)	Axial (Max.) (inch)
3 and 4	1.0 to 5.0	0 to 0.5	0.0007	0.0028
5 thru 12	1.0 to 15.0	0 to 1.0	0.0007	0.0028
14 thru 20	1.0 to 25.0	0 to 2.0	0.0010	0.0040

**Bearing Materials:**  
**Liner** = See Table 2 for liner options  
**Outer Race** = 17-4PH (AMS 5643) Condition H1150  
**Ball** = 440C (AMS5630) HRC 55/62 or PH13-8Mo CRES (AMS5629) Condition H1000, Passivate PH13-8Mo per QQ-P-35  
 Chrome plate option per QQ-C-35 Class 2, (.0002-.0005 thick)  
**Note 1: Load Ratings Shown are with Karon B Liner System**

# KARON Lined Spherical Bearings

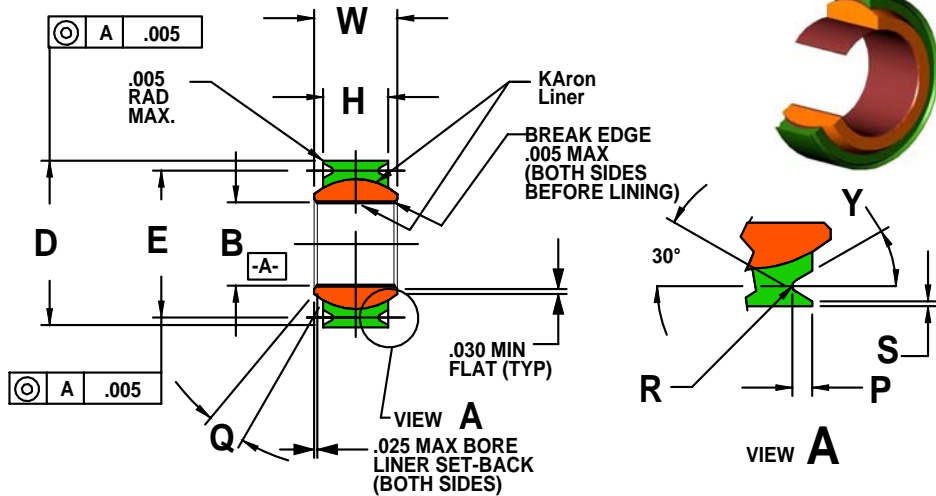

**KR-CNG/1 Series – Narrow, Grooved Outer Race**  
**Lined Bore, -65° F to +325° F**  
**KR4 to KR16 Qualified to SAE AS81820 with Karon B Liner**

Part Number Example:  
**KR 6 - CN G /1 B P W K T Y**

KR = Basic Karon Spherical Bearing Prefix  
 6 = .3750 ID (ID in 1/16 increments)  
 CN = Narrow Outer Race  
 G = Grooved Outer Race  
 /1 = Karon Lined Bore (ID)  
 B = Karon B liner (See Table 2 for liner options)  
 P = Cadmium Plated OD per QQ-P-416 Option  
 W = Chrome Plated Ball OD Option  
 K = Low Breakaway Torque Option  
 T = .010 Oversize OD Option  
 Y = PH13-8Mo Ball option (440C no letter)

Bearing Size	Nominal Bore	T	U
		.010 OD Oversize +.0000 -.0005	.020 OD Oversize +.0000 -.0005
-3	.1910	.5725	.5825
-4	.2510	.6662	.6762
-5	.3135	.7600	.7700
-6	.3760	.8225	.8325
-7	.4385	.9162	.9262
-8	.5010	1.0100	1.0200
-9	.5635	1.1037	1.1137
-10	.6230	1.1975	1.2075
-12	.7510	1.4475	1.4575
-14	.8760	1.5725	1.5825
-16	1.0010	1.7600	1.7700
-20	1.2510	2.0100	2.0200

AS81820/1 M81820/1 (REF)	B	D	W	H	E	Q°					
BEARING NUMBERS	BORE DIA	OUTSIDE DIA	BALL WIDTH	RACE WIDTH	BALL DIA (REF)	GROOVE DIA +.000 -.008	RADIAL DYNAMIC LOAD RATING (LBS) See Note 1	APPROX. MISALIGNMENT (°)	RADIAL STATIC LIMIT LOAD (LBS) See Note 1	AXIAL STATIC LIMIT LOAD (LBS) See Note 1	APPROX WEIGHT (LBS)
	KR3-CNG/1	.1910	.5625	.281	.218	.406	.500	1500	10	3975	150
KR4-CNG/1	.2510	.6562	.343	.250	.500	.594	2650	10	6040	430	.02
KR5-CNG/1	.3135	.7500	.375	.281	.562	.650	3700	10	8750	700	.03
KR6-CNG/1	.3760	.8125	.406	.312	.625	.712	4900	9	10540	1100	.04
KR7-CNG/1	.4385	.9062	.437	.343	.687	.806	6700	8	13200	1400	.05
KR8-CNG/1	.5010	1.0000	.500	.390	.781	.876	8250	8	17900	2100	.07
KR9-CNG/1	.5635	1.0937	.562	.437	.875	.970	10500	8	23200	3680	.09
KR10-CNG/1	.6260	1.1875	.625	.500	.968	1.063	13250	8	30500	4720	.12
KR12-CNG/1	.7510	1.4375	.750	.593	1.187	1.313	19400	8	46400	6750	.21
KR14-CNG/1	.8760	1.5625	.875	.703	1.312	1.438	26750	8	62200	9350	.27
KR16-CNG/1	1.0010	1.7500	1.000	.797	1.500	1.626	35250	9	82200	12160	.39
KR20-CNG/1	1.2510	2.0000	1.093	.942	1.781	1.876	47800	6	95600	15500	.53

Bearing Size	No-Load Rotational Breakaway Torque In.-lbs.		Bearing Clearances "K" Type Only	
	Standard	"K" Type	Radial (Max.)	Axial (Max)
			(Inch)	(Inch)
3 and 4	0.25 to 5.0	0 to 0.5	0.0007	0.0028
5 thru 12	0.25 to 8.0	0 to 1.0	0.0007	0.0028
14 thru 20	0.25 to 12	0 to 2.0	0.0010	0.0040

Bearing Size	P (in)	R (in)	S (in)	Y°
	+.000 -.010	+.000 -.005	Ref.	
3 and 4	.025	.010	.010	20/30
5 thru 7	.035	.017	.020	30
8 thru 20	.055	.017	.020	30

**Bearing Materials:**

Liner = See Table 2 for liner options  
 Outer Race = 17-4PH (AMS5643) H1150 Cond.  
 Ball = 440C (AMS5630) HRC 55/62 or PH13-8Mo (AMS5629) H1000 Cond. Passivate PH13-8Mo per QQ-P-35,  
 Chrome option per QQ-C-320 Class 2 (.0002-.0005 thick).

**Note 1: Load Ratings Shown are with Karon B Liner System**

# KARON Lined Spherical Bearings

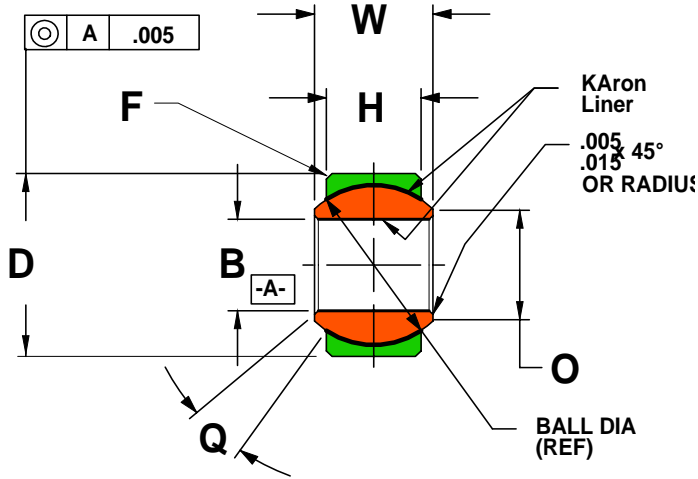

**KR-CW/2 Series – Wide, Chamfered Outer Race**  
**Lined Bore, -65° F to +325° F**  
**KR5 to KR16 Qualified to SAE AS81820 with Karon B Liner**

Part Number Example:

**KR 6 - CW /2 B P W K I Y**

**KR** = Basic Karon Spherical Bearing Prefix  
**6** = .3750 ID (ID in 1/16 increments)  
**CW** = Wide Chamfered Outer Race  
**/2** = Karon Lined Bore  
**B** = Karon B liner (See Table 2 for liner options)  
**P** = Cadmium Plated OD per QQ-P-416 Option  
**W** = Chrome Plated Ball OD Option  
**K** = Low Breakaway Torque Option  
**T** = .010 Oversize OD Option  
**Y** = PH13-8Mo Ball option (440C no letter)

Bearing Size	Maximum Bore	T	U
		.010 OD Oversize +.0000 -.0005	.020 OD Oversize +.0000 -.0005
-3	.1910	.6350	.6450
-4	.2510	.6350	.6450
-5	.3135	.6975	.7075
-6	.3760	.8225	.8325
-7	.4385	.9475	.9575
-8	.5010	1.0100	1.0200
-9	.5635	1.1350	1.1450
-10	.6260	1.1975	1.2075
-12	.7510	1.3850	1.3950
-14	.8760	1.6350	1.6450
-16	1.0010	2.1350	2.1450
-20	1.2510	2.3850	2.3950

AS81820/2 M81820/2 (Ref)	B	D	W	H		F		Q°			
BEARING NUMBERS	BORE DIA	OUTSIDE DIA	BALL WIDTH	RACE WIDTH	BALL DIA (REF)	CHAMFER X 45°	RADIAL DYNAMIC LOAD RATING (LBS) See Note 1	APPROX. MISALIGNMENT (°)	RADIAL STATIC LIMIT LOAD (LBS) See Note 1	AXIAL STATIC LIMIT LOAD (LBS) See Note 1	APPROX WEIGHT (LBS)
	+.0000 -.0010	+.0000 -.0005	+.000 -.002	+.005 -.005							
KR3-CW/2	.1910	.6250	.437	.327	.531		1500	15	3975	1770	.03
KR4-CW/2	.2510	.6250	.437	.327	.531	.010/.020	2650	15	5550	1770	.03
KR5-CW/2	.3135	.6875	.437	.317	.562		4450	14	9250	1640	.04
KR6-CW/2	.3760	.8125	.500	.406	.687		6200	8	13000	2630	.06
KR7-CW/2	.4385	.9375	.562	.442	.781		8250	10	17250	3650	.08
KR8-CW/2	.5010	1.0000	.625	.505	.875	.020/.030	10600	9	21400	4970	.10
KR9-CW/2	.5635	1.1250	.687	.536	1.000		13200	10	25600	5370	.14
KR10-CW/2	.6260	1.1875	.750	.567	1.062		15150	12	29000	6130	.16
KR12-CW/2	.7510	1.3750	.875	.630	1.218		24500	13	37000	7730	.24
KR14-CW/2	.8760	1.6250	.875	.755	1.375	.030/.040	28750	6	56000	10800	.35
KR16-CW/2	1.0010	2.1250	1.375	1.005	1.875		49300	12	103300	19300	.97
KR20-CW/2	1.2510	2.3750	1.5000	1.130	2.093		67500	14	136900	21400	1.10

Bearing Size	No-Load Rotational Breakaway Torque In.-lbs.		Bearing Clearances "K" Type Only	
	Standard	"K" Type	Radial (Max.) (inch)	Axial (Max) (inch)
3 to 12	1.0 to 15.0	0 to 1.0	0.0007	0.0021
14 thru 20	1.0 to 25.0	0 to 2.0	0.0010	0.0030

### Bearing Materials:

**Liner** = See Table 2 for liner options

**Outer Race** = 17-4PH (AMS5643) H1150 Cond.

**Ball** = 440C (AMS5630) HRC 55/62 or PH13-8Mo (AMS5629) H1000 Cond.

Passivate PH13-8Mo per QQ-P-35, Chrome option per QQ-C-320 Class 2 (.0002-.0005 thick).

**Note 1:** Load Ratings Shown are with Karon B Liner System

# KARON Lined Spherical Bearings

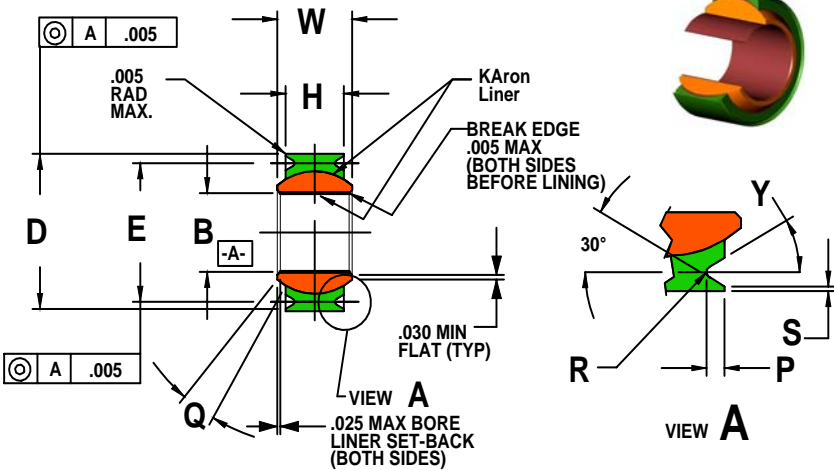

**KR-CWG/3 Series – Wide, Grooved Outer Race**  
**Lined Bore, -65° F to +325° F**  
**KR5 to KR16 Qualified to SAE AS81820 with Karon B Liner**

Part Number Example:  
**KR 6 - CW G / 3 B P W K I Y**

**KR** = Basic Karon Spherical Bearing Prefix  
**6** = .3750 ID (ID in 1/16 increments)  
**CW** = Chamfered Wide Outer Race  
**G** = Grooved Outer Race  
**/3** = Karon Lined Bore (ID)  
**B** = Karon B liner (See Table 2 for liner options)  
**P** = Cadmium Plated OD per QQ-P-416 Option  
**W** = Chrome Plated Ball OD Option  
**K** = Low Breakaway Torque Option  
**T** = .010 Oversize OD Option  
**Y** = PH13-8Mo Ball option (440C no letter)

Bearing Size	Nominal Bore	T	U
		.010 OD Oversize +.0000 -.0005	.020 OD Oversize +.0000 -.0005
-4	.2510	.6350	.6450
-5	.3135	.6975	.7075
-6	.3760	.8225	.8325
-7	.4385	.9475	.9575
-7A	.4385	.9162	.9262
-8	.5010	1.0100	1.0200
-9	.5635	1.1350	1.1450
-10	.6230	1.1975	1.2075
-12	.7510	1.3850	1.3975
-14	.8760	1.6350	1.6450
-16	1.0010	2.1350	2.1450
-20	1.2510	2.3850	2.3975

AS81820/3 M81820/3	B	D	W	H		E		Q°			
BEARING NUMBERS	BORE DIA +.0000 -.0010	OUTSIDE DIA +.0000 -.0005	BALL WIDTH +.000 -.002	RACE WIDTH +.005 -.005	BALL DIA (REF)	GROOVE DIA +.000 -.008	RADIAL DYNAMIC LOAD RATING (LBS) See Note 1	APPROX. MISALIGNMENT (°)	RADIAL STATIC LIMIT LOAD (LBS) See Note 1	AXIAL STATIC LIMIT LOAD (LBS) See Note 1	APPROX WEIGHT (LBS)
KR3-CWG/3	.1910	.6250	.437	.327	.531	.563	1500	15	3975	1770	.03
KR4-CWG/3	.2510	.6250	.437	.327	.531	.563	2650	15	7100	1770	.03
KR5-CWG/3	.3135	.6875	.437	.317	.562	.622	4450	14	9300	1640	.04
KR6-CWG/3	.3760	.8125	.500	.406	.687	.712	6200	8	13000	2630	.06
KR7-CWG/3	.4385	.9375	.562	.442	.781	.837	8250	10	17300	3650	.08
KR7A-CWG/3	.4385	.9062	.562	.442	.781	.806	8250	10	17300	3650	.08
KR8-CWG/3	.5010	1.0000	.625	.505	.875	.900	10500	9	21400	4970	.10
KR9-CWG/3	.5635	1.1250	.687	.536	1.000	1.025	13200	10	26500	5370	.14
KR10-CWG/3	.6260	1.1875	.750	.567	1.062	1.087	16150	12	29000	6130	.16
KR12-CWG/3	.7510	1.3750	.875	.630	1.218	1.251	24500	13	37000	7730	.24
KR14-CWG/3	.8760	1.6250	.875	.755	1.375	1.501	25750	6	56000	10800	.35
KR16-CWG/3	1.0010	2.1250	1.375	1.005	1.875	2.001	49300	12	103000	19300	.97
KR20-CWG/3	1.2510	2.3750	1.500	1.130	2.093	2.251	67500	14	140600	21400	1.10

Bearing Size	No-Load Rotational Breakaway Torque In.-lbs.		Bearing Clearances "K" Type Only	
	Standard	"K" Type	Radial (Max.) (Inch)	Axial (Max) (Inch)
			0.0007	0.0021
3 thru 12	1.0 to 15.0	0 to 1.0	0.0007	0.0021
14 thru 20	0.25 to 12	0 to 2.0	0.0010	0.0030

Bearing Size	P (inch)	R (inch)	S (inch)	Y°
	+.000 -.010	+.000 -.005	Ref.	
3 and 4	.025	.010	.010	20/30
5	.035	.017	.020	30
6 thru 20	.055	.017	.020	30

**Bearing Materials:**  
**Liner** = See Table 2 for liner options  
**Outer Race** = 17-4PH (AMS5643) H1150 Cond.  
**Ball** = 440C (AMS5630) HRC 55/62 or PH13-8Mo (AMS5629) H1000 Cond. Passivate PH13-8Mo per QQ-P-35, Chrome option per QQ-C-320 Class 2 (.0002-.0005 thick).

**Note 1: Load Ratings Shown are with Karon B Liner System**

# KARON Lined Spherical Bearings

## KR-CE Series – Extended Inner Race, High Misalignment, Chamfered Outer Race

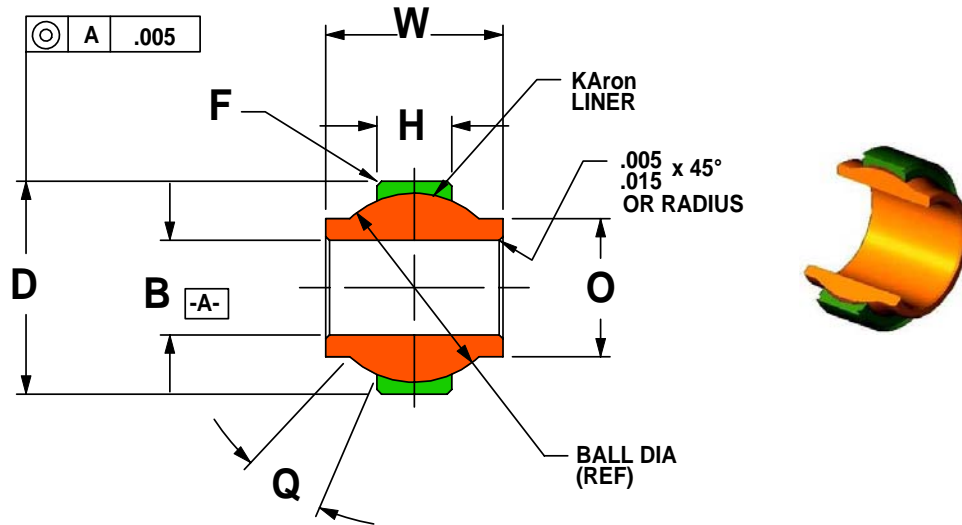

Part Number Example:

**KR 6- CE B P W**

**KR** = Basic Karon Spherical Bearing Prefix  
**6** = .3750 ID (ID in 1/16 increments)  
**CE** = Extended Inner Race (Ball) Width, Chamfered Outer Race  
**B** = Karon B liner (See Table 2 for liner options)  
**P** = Cadmium Plated OD per QQ-P-416 Option  
**W** = Chrome Plated Ball OD Option

BEARING NUMBERS	B	D	W	H	O	BALL DIA (REF)	F	See Note 1	Q°	See Note 1	See Note 1	APPROX WEIGHT (LBS)
	BORE DIA	OUTSIDE DIA	BALL WIDTH	RACE WIDTH	SHOULDER DIA (MIN)							
	+0.0000 -0.0005	+0.0000 -0.0005	+0.000 -0.002	+0.005 -0.005								
KR3-CE	.1900	.5625	.500	.205	.319	.437		2720	15	3740	380	.03
KR4-CE	.2500	.7400	.593	.255	.390	.593	.010/.020	4420	25	7400	560	.04
KR5-CE	.3125	.6875	.625	.255	.418	.593		4420	20	7400	560	.04
KR6-CE	.3750	.9060	.813	.345	.512	.781		7550	22	13200	1380	.06
KR8-CE	.5000	1.1250	.937	.396	.730	1.000	.020/.030	10700	20	21800	2200	.16
KR10-CE	.6250	1.3750	1.200	.567	.856	1.219		20100	20	39200	7600	.25
KR12-CE	.7500	1.5625	1.280	.620	.970	1.375	.030/.040	22800	20	47000	10400	.45
KR16-CE	1.000	2.1250	1.875	.835	1.278	1.875		37100	22	86200	14000	.80

Bearing Size	No-Load Breakaway Torque (in.-lbs)
3 & 4	0-5
5 thru 12	0-15
16	0-24

### Bearing Materials:

**Liner** = See Table 2 for liner options

**Outer Race** = 17-4PH (AMS 5643) Condition H1150

**Ball** = 440C (AMS 5630) Rc 55 Minimum

Chrome option per QQ-C-320 Class 2 (.0002-.0005 thick).

**Note 1: Load Ratings Shown are with Karon B liner System**

# KARON Lined Spherical Bearings

## KR-CEG Series – Extended Inner Race, High Misalignment, Grooved Outer Race

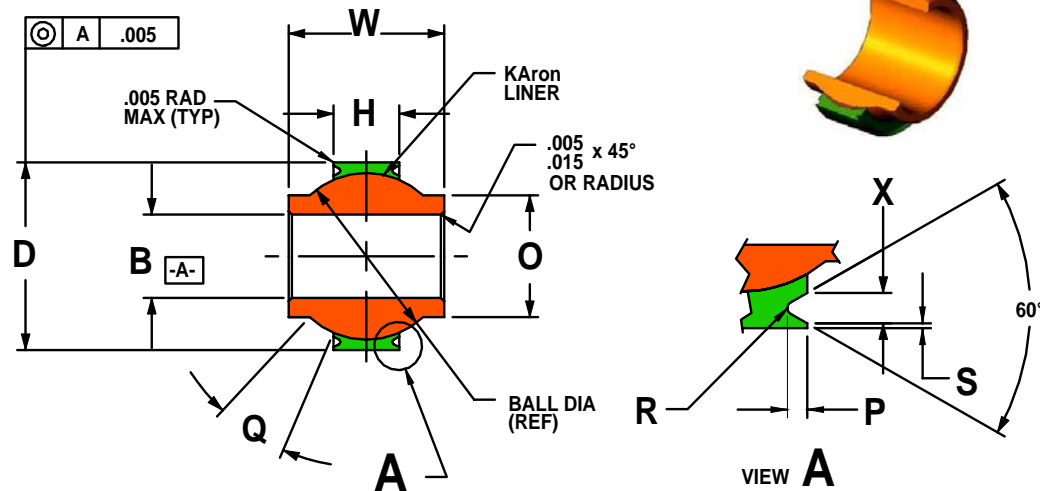

Part Number Example:

**KR 6-CE G B P W**

- KR** = Basic Karon Spherical Bearing Prefix
- 6** = .3750 ID (ID in 1/16 increments)
- CE** = Extended Inner Race (Ball) Width
- G** = Grooved Outer Race
- B** = Karon B liner (See Table 2 for liner options)
- P** = Cadmium Plated OD per QQ-P-416 Option
- W** = Chrome Plated Ball OD Option

BEARING NUMBERS	B	D	W	H	O	BALL DIA (REF)	See Note 1	Q°	See Note 1	See Note 1	APPROX WEIGHT (LBS)
	BORE DIA	OUTSIDE DIA	BALL WIDTH	RACE WIDTH	SHOULDER DIA (MIN)		RADIAL DYNAMIC LOAD RATING (LBS)	APPROX. MISALIGNMENT (°)	RADIAL STATIC LIMIT LOAD (LBS)	AXIAL STATIC LIMIT LOAD (LBS)	
	+.0000 -.0005	+.0000 -.0005	+.000 -.002	+.005 -.005							
KR3-CEG	.1900	.5625	.500	.205	.319	.437	2720	15	3740	380	.03
KR4-CEG	.2500	.7400	.593	.255	.390	.593	4420	25	7400	560	.04
KR5-CEG	.3125	.6875	.625	.255	.418	.593	4420	20	7400	560	.04
KR6-CEG	.3750	.9060	.813	.345	.512	.781	7550	22	13200	1380	.06
KR8-CEG	.5000	1.1250	.937	.396	.730	1.000	10700	20	21800	2200	.16
KR10-CEG	.6250	1.3750	1.200	.567	.856	1.219	20100	20	39200	7600	.25
KR12-CEG	.7500	1.5625	1.280	.620	.970	1.375	22800	20	47000	10400	.45
KR16-CEG	1.000	2.1250	1.875	.835	1.278	1.875	37100	22	86200	14000	.80

Bearing Size	P	R	S	X
		+.000 -.015	+.000 -.010	+.000 -.010
3 and 8	.030	.015	.020	.045
10 thru 12	.040	.020	.030	.055
16	.060	.020	.030	.080

Bearing Size	No-Load Breakaway Torque (in.-lbs)
3 & 4	0-5
5 thru 12	0-15
16	0-24

### Bearing Materials:

**Liner** = See Table 2 for liner options

**Outer Race** = 17-4PH (AMS 5643) Condition H1150

**Ball** = 440C (AMS 5630) Rc 55 Minimum

Chrome option per QQ-C-320 Class 2 (.0002-.0005 thick).

**Note 1: Load Ratings Shown are with Karon B Liner System**

## KARON Lined Spherical Bearings

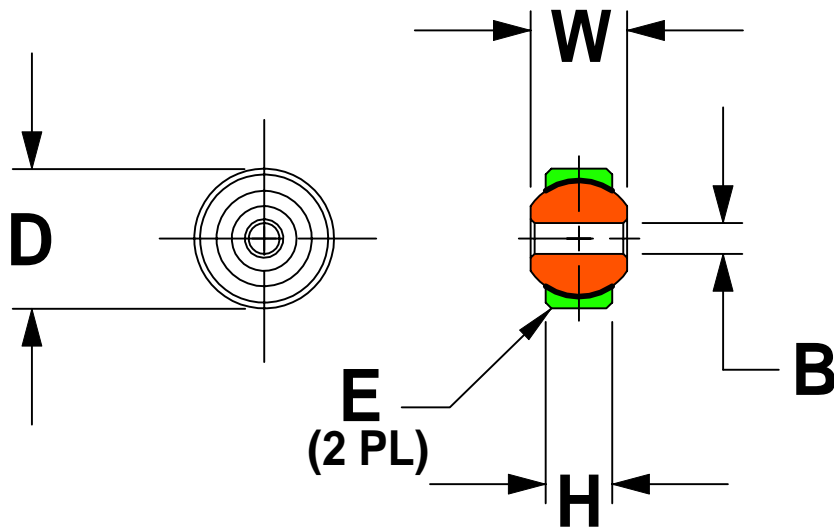

## KR-C Series – Spherical Bearing, Miniature

PART NUMBER EXAMPLE:

KR 094 - C B

KR = BASIC KARON PART NUMBER PREFIX

094 = 0.094 ID (BORE SIZE IN 0.001 INCH INCREMENTS)

C = MINIATURE SPHERICAL BEARING CARTRIDGE

B = KARON B LINER, See Table 2 for liner options

KR( ) C SERIES	B	D	W	H	E	SUGGESTED MATING HOUSING BORE SIZE	ULT. STATIC LOAD (LBS) SEE NOTES 1 & 2
BEARING NUMBER	BORE DIA	OUTER RACE DIA	BALL WIDTH	BODY WIDTH	CHAMFER X 45°		
	+ .0000 - .0005	+ .0000 - .0005	+ .000 - .005	+ .005 - .000	+ .010 - .000	+ .0000 - .0005	
KR088-C	.0880	.2500	.125	.100	.010	.2500	550
KR094-C	.0938	.2812	.155	.120	.010	.2812	775
KR125-C	.1250	.3620	.250	.172	.010	.3620	2050
KR156-C	.1560	.4687	.281	.187	.010	.4687	2550

	BALL	OUTER RACE	LINER
<b>MATERIAL</b>	AMS 5630 (440C)	AMS 5643 (17-4PH)	<b>KARON</b>
<b>HARDNESS</b>	Rc 55 MIN	Rc 28 MIN	See Table 2 for liner options

### NOTES

1. Load ratings shown are based on Karon B liner system, See Table 2 for liner options
2. Loads shown are based on bearing components only, bolt/pin shear is not considered.
3. No load rotational breakaway torque = 1 inch pound maximum

# KARON Lined Rod End Bearings

## KR-F Series – Rod End, Female Dimensionally Equivalent to Mil-B-81935/2

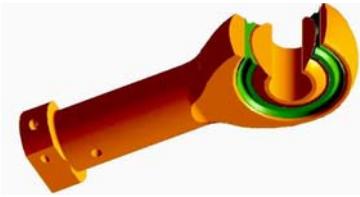
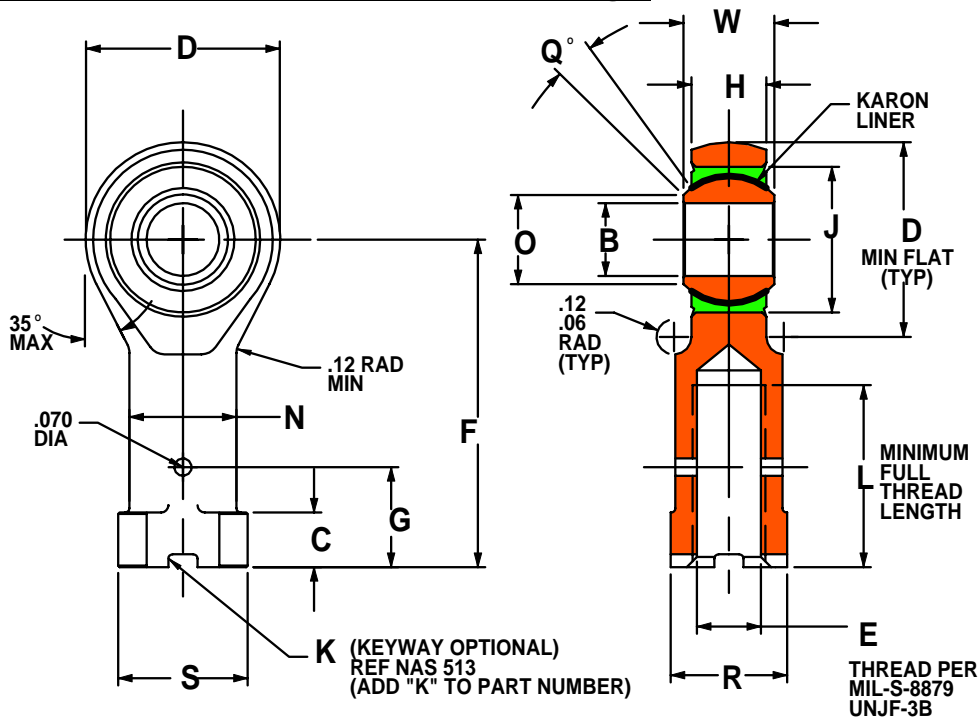

PART NUMBER EXAMPLE:

**KR 6 - F S B L K**

"K" FOR KEYWAY  
 "L" FOR LEFT HAND THREAD  
 KARON B LINER (See Table 2 for liner options)  
 ROD END BODY MATERIAL, "S" OR "A"  
 FEMALE ROD END BODY  
 .3750 DIA BORE, BORE SIZE IN 1/16 INCREMENTS  
 BASIC ROD END PART NUMBER PREFIX

M81935/2 SIZE	B	D	L	E	F	N	W	H	O	G	C	R	Q°	S	J	LOAD RATINGS (LBS) See Note 1			WEIGHT MAX (LBS)
																ULT. STATIC	FATIGUE	AXIAL PROOF	
BEARING NUMBER	BORE DIA + .0000 - .0005	ROD END DIA. + .010 - .010	THREAD LENGTH MIN	THREAD SIZE	BODY LENGTH + .010 - .010	SHANK DIA + .010 - .010	BALL WIDTH + .000 - .002	BODY WIDTH + .005 - .005	MIN BALL FLAT	+ .010 - .010	+ .010 - .062	+ .002 - .010	MIN	REF DIA OR DISTANCE ACROSS CORNERS	MAX HOUSING ID	ULT. STATIC	FATIGUE	AXIAL PROOF	WEIGHT MAX (LBS)
KR3-F	.1900	.806	.750	5/16-24	1.375	.422	.437	.337	.300	.375	.188	.437	15	.500	.6250	2360	1470	1000	.080
KR4-F	.2500	.806	.750	5/16-24	1.469	.422	.437	.337	.300	.375	.188	.437	15	.500	.6250	4860	2380	1000	.084
KR5-F	.3125	.900	.875	3/8-24	1.625	.485	.437	.327	.360	.437	.250	.500	14	.580	.6875	7180	3020	1100	.102
KR6-F	.3750	1.025	1.000	3/8-24	1.812	.547	.500	.416	.466	.437	.250	.562	8	.660	.8125	8550	3570	1660	.161
KR7-F	.4375	1.150	1.125	7/16-20	2.000	.610	.562	.452	.537	.500	.250	.625	10	.720	.9062	12000	4800	1850	.212
KR8-F	.5000	1.337	1.250	1/2-20	2.250	.735	.625	.515	.607	.562	.250	.750	9	.890	1.0000	19500	8260	2040	.325
KR10-F	.6250	1.525	1.375	5/8-18	2.500	.860	.750	.577	.747	.687	.375	.875	12	1.020	1.1875	21900	9180	2430	.481
KR12-F	.7500	1.775	1.625	3/4-16	2.875	.985	.875	.640	.845	.812	.375	1.000	13	1.160	1.3750	29300	11600	2810	.673
KR14-F	.8750	2.025	1.875	7/8-14	3.375	1.110	.875	.765	.995	.937	.500	1.125	6	1.300	1.6250	34500	13100	3320	.959
KR16-F	1.0000	2.775	2.125	1 1/4-12	4.125	1.688	1.375	1.015	1.269	1.312	.563	1.750	12	2.020	2.1250	80300	30400	4340	2.717

	BALL	RACE	LINER	BODY	DESIGNATION
MATERIAL	AMS 5630 (440C)	AMS 5643 (17-4PH)	KARON	AMS 5643 (17-4PH)	ADD SUFFIX
HARDNESS	Rc 55 MIN	Rc 28 MIN	See Table 2 for liner options	Rc 39 MIN PASSIVATED	<b>S</b> TO P/N FOR 17-4PH
MATERIAL	AMS 5630 (440C)	AMS 5643 (17-4PH)	KARON	4340 OR 4230 ALLOY STEEL	ADD SUFFIX
HARDNESS	Rc 55 MIN	Rc 28 MIN	See Table 2 for liner options	Rc 39 MIN CAD. PLATED	<b>A</b> TO P/N FOR ALLOY STEEL

NOTE 1: Load ratings shown are based on Karon B liner system

BEARING SIZE	No Load Rotational Breakaway Torque (In-Lbs)
3 & 4	0.5 TO 6.0
5 TO 12	1 TO 15
14 TO 16	1 TO 24

# KARON Lined Rod End Bearings

## KR-M Series – Rod End, Male Dimensionally Equivalent to Mil-B-81935/1

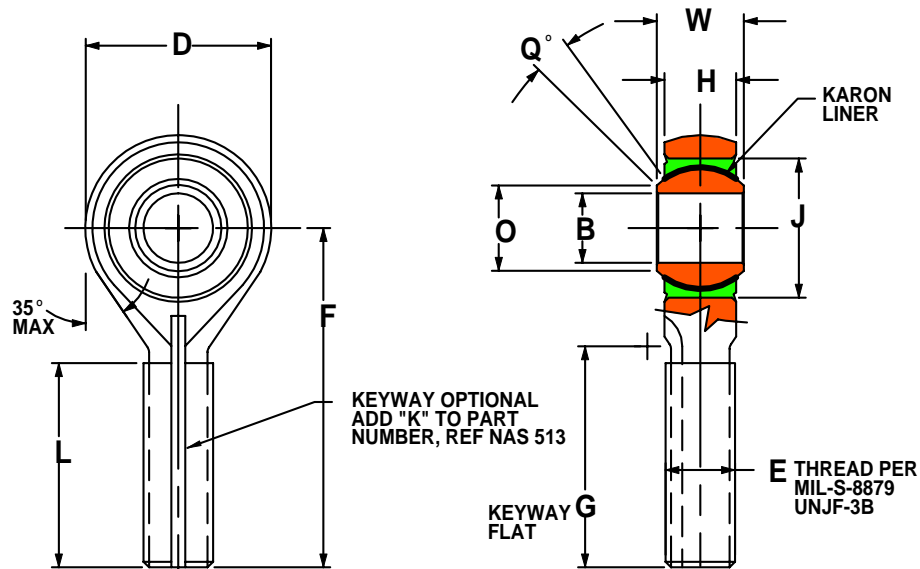

PART NUMBER EXAMPLE:

**KR 6-M S B L K**

- "K" FOR KEYWAY
- "L" FOR LEFT HAND THREAD
- KARON B LINER (See Table 2 for liner options)
- ROD END BODY MATERIAL, "S" OR "A"
- MALE ROD END BODY
- .3750 DIA BORE, BORE SIZE IN 1/16 INCH INCREMENTS
- BASIC ROD END PART NUMBER PREFIX

M81935/1 SIZE	B	D	L	E	F	W	H	O	G	Q°	J	LOAD RATINGS (LBS) See Note 1			WEIGHT MAX (LBS)
BEARING NUMBER	BORE DIA	ROD END DIA.	THREAD LENGTH MIN	THREAD SIZE	BODY LENGTH	BALL WIDTH	BODY WIDTH	MIN BALL FLAT	KEYWAY FLAT	MIN	MAX HOUSING ID	ULT. STATIC	FATIGUE	AXIAL PROOF	
	+0.000 -0.005	+0.010 -0.010							+0.000 -0.020						
KR3-M	.1900	.806	.968	5/16-24	1.562	.437	.337	.300	.980	15	.6250	2360	1470	1000	.080
KR4-M	.2500	.806	.968	5/16-24	1.562	.437	.337	.300	.980	15	.6250	4860	2380	1000	.084
KR5-M	.3125	.900	1.187	5/16-24	1.875	.437	.327	.360	1.270	14	.6875	7180	3020	1100	.102
KR6-M	.3750	1.025	1.187	3/8-24	1.938	.500	.416	.466	1.235	8	.8125	8550	3570	1660	.161
KR7-M	.4375	1.150	1.281	7/16-20	2.125	.562	.452	.537	1.402	10	.9062	12000	4800	1850	.212
KR8-M	.5000	1.337	1.468	1/2-20	2.438	.625	.515	.607	1.589	9	1.0000	19500	8260	2040	.325
KR10-M	.6250	1.525	1.562	5/8-18	2.625	.750	.577	.747	1.683	12	1.1875	21900	9180	2430	.481
KR12-M	.7500	1.775	1.687	3/4-16	2.875	.875	.640	.845	1.808	13	1.3750	29300	11600	2810	.673
KR14-M	.8750	2.025	2.000	7/8-14	3.375	.875	.765	.995	2.121	6	1.6250	34500	13100	3320	.959
KR16-M	1.0000	2.775	2.343	1 1/4-12	4.125	1.375	1.015	1.269	2.464	12	2.1250	80300	30400	4340	2.717

	BALL	RACE	LINER	BODY	DESIGNATION
<b>MATERIAL</b>	AMS 5630 (440C)	AMS 5643 (17-4PH)	<b>KARON</b>	<b>AMS 5643</b> (17-4PH)	<b>ADD SUFFIX S</b>
<b>HARDNESS</b>	Rc 55 MIN	Rc 28 MIN	See Table 2 for liner options	Rc 39 MIN PASSIVATED	TO P/N FOR 17-4PH
<b>MATERIAL</b>	AMS 5630 (440C)	AMS 5643 (17-4PH)	<b>KARON</b>	4340 OR 4230 ALLOY STEEL	<b>ADD SUFFIX A</b>
<b>HARDNESS</b>	Rc 55 MIN	Rc 28 MIN	See Table 2 for liner options	Rc 39 MIN CAD. PLATED	TO P/N FOR ALLOY STEEL

BEARING SIZE	No Load Rotational Breakaway Torque (In-Lbs)
3 & 4	0.5 TO 6.0
5 TO 12	1 TO 15
14 TO 16	1 TO 24

NOTE 1: Load ratings shown are based on Karon B liner system

# KARON Lined Rod End Bearings

## KR-FS Series – Rod End, Female, Miniature

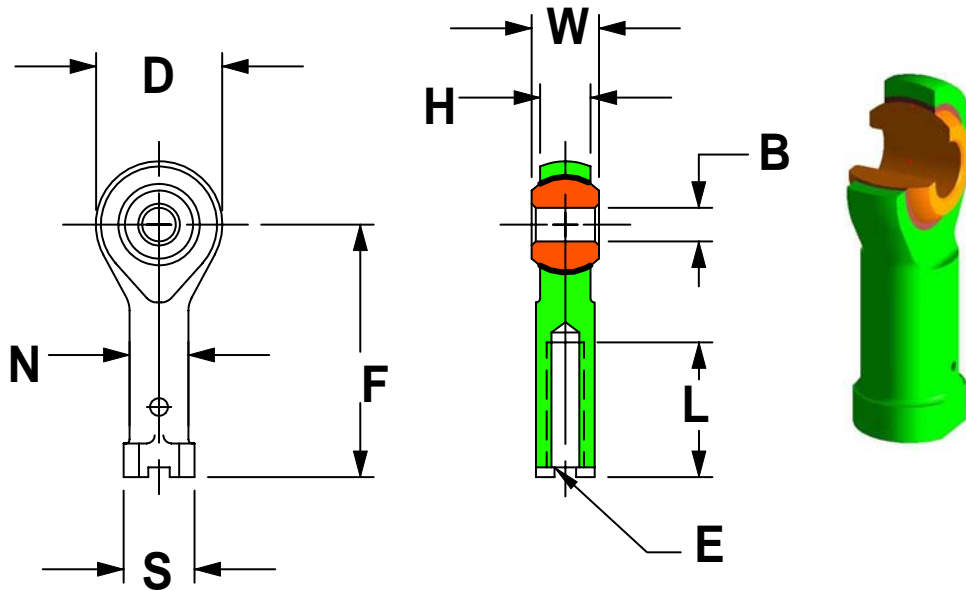

PART NUMBER EXAMPLE:  
**KR 094 - FS B L K**

KR = BASIC KARON PART NUMBER PREFIX  
 094 = BORE SIZE IN 0.001 INCH INCREMENTS  
 FS = MINIATURE FEMALE ROD END BODY  
 B = KARON B LINER, SEE TABLE 2 FOR LINER OPTIONS  
 L = LEFT HAND THREAD OPTION  
 K = KEYWAY OPTION

KR( ) FS SERIES	B	D	L	E	F	N	W	H	S	ULT. STATIC LOAD (LBS) SEE NOTES 1 & 2
BEARING NUMBER	BORE DIA +.0000 -.0005	ROD END DIA. +.010 -.010	THREAD LENGTH +.031 -.031	THREAD SIZE UNF-3B	BODY LENGTH +.010 -.010	SHANK DIA +.010 -.010	BALL WIDTH +.000 -.005	BODY WIDTH +.005 -.005	REF DIA OR DISTANCE ACROSS CORNERS	
KR047-FS	.0469	.189	.212	0-80	.357	.156	.109	.082	.200	225
KR094-FS	.0938	.250	.260	3-56	.491	.187	.125	.084	.230	400
KR125-FS	.1250	.469	.500	6-32	.937	.218	.250	.187	.263	850
KR156-FS	.1560	.562	.625	8-32	1.125	.250	.281	.219	.295	1050

	BALL	ROD END BODY	LINER
MATERIAL	AMS 5630 (440C)	AMS 5643 (17-4PH)	KARON
HARDNESS	Rc 55 MIN	Rc 28 MIN	SEE TABLE 2 FOR LINER OPTIONS

### NOTES

1. Load ratings shown are based on KARON B liner system
2. Loads shown are based on bearing components only, bolt/pin shear is not considered.
3. No load rotational breakaway torque = 1 inch pound maximum

## KARON Lined Rod End Bearings

## KR-MS Series – Rod End, Male, Miniature

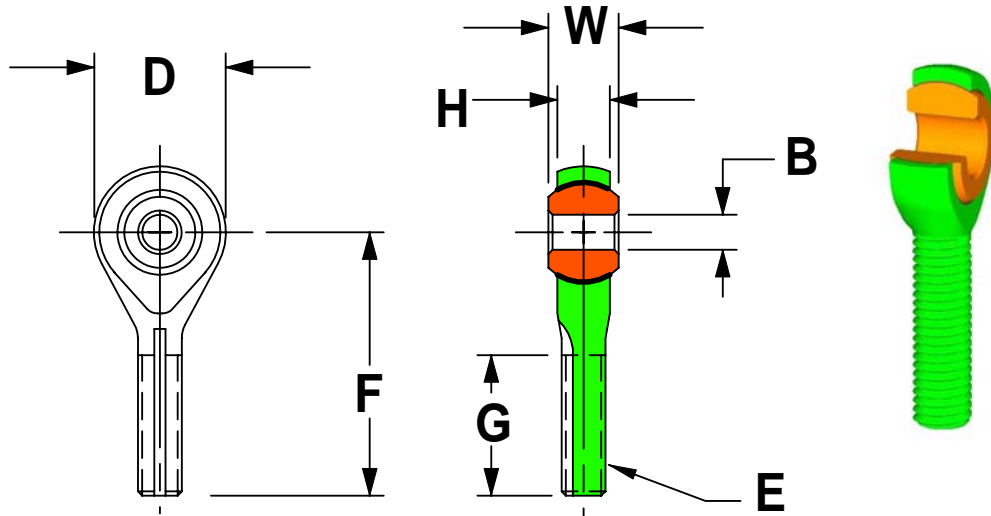

PART NUMBER EXAMPLE:  
**KR 094-MS B L K**

**KR** = BASIC KARON PART NUMBER PREFIX  
**094** = BORE SIZE IN 0.001 INCH INCREMENTS  
**MS** = MINIATURE MALE ROD END BODY  
**B** = KARON B LINER, SEE TABLE 2 FOR LINER OPTIONS  
**L** = LEFT HAND THREAD OPTION  
**K** = KEYWAY OPTION

KR( ) FM SERIES	B	D	G	E	F	W	H	ULT. STATIC LOAD (LBS) SEE NOTES 1 & 2
BEARING NUMBER	BORE DIA +.0000 -.0005	ROD END DIA. +.010 -.010	THREAD LENGTH +.031 -.031	THREAD SIZE UNF-3A	BODY LENGTH +.010 -.010	BALL WIDTH +.000 -.005	BODY WIDTH +.005 -.005	
<b>KR047-MS</b>	.0469	.189	.212	0-80	.357	.109	.082	225
<b>KR094-MS</b>	.0938	.250	.260	3-56	.491	.125	.084	400
<b>KR125-MS</b>	.1250	.469	.500	6-32	.937	.250	.187	850
<b>KR156-MS</b>	.1560	.562	.625	8-32	1.125	.281	.219	1050

	BALL	ROD END BODY	LINER
<b>MATERIAL</b>	AMS 5630 (440C)	AMS 5643 (17-4PH)	<b>KARON</b>
<b>HARDNESS</b>	Rc 55 MIN	Rc 28 MIN	SEE TABLE 2 FOR LINER OPTIONS

### NOTES

1. Load ratings shown are based on Karon B liner system.
2. Loads shown are based on bearing components only, bolt/pin shear is not considered.
3. No load rotational breakaway torque = 1 inch pound maximum

# KARON Lined Journal Bearings

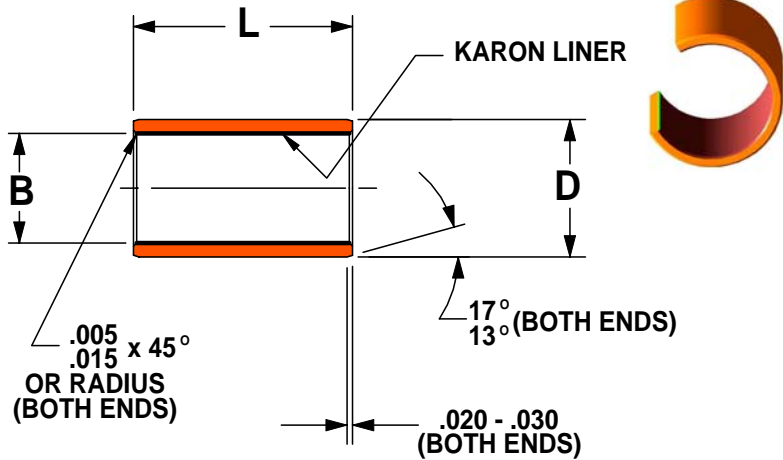

## KRJ-Series – Sleeve, Non-Flanged, Lined Bore Qualified to SAE AS81934/1 with Karon B and Mil-B-8943 with Karon V, M, and RP

BEARING MATERIALS				
	MATERIAL	CONDITION	SURFACE FINISH	P/N SYMBOL
OUTER HOUSING	AMS 5643 17-4PH CRES	H1150	PASSIVATE PER QQ-P-35 OR CAD PLATE PER QQ-P-416	S
	QQ-A-200/3 OR QQ-A-225/8 2024 ALUMINUM	T851/T8511	ANODIZE PER MIL-A- 8625 TYPE I OR 11 OR CHEM FILM PER MIL-C-5541	Y
LINER	KARON	N/A	N/A	SEE TABLE 2 FOR LINER OPTIONS

M81934/1 BEARING NUMBER	B BORE DIA + .0000 - .0010	D OUTER DIA. See NOTE 1	T .010 O'SIZE DIA D See NOTE 1	U .020 O'SIZE DIA D See NOTE 1	L Mil Spec Length Limits (Suggested)		WEIGHT LBS/INCH (REF)	
					MIN	MAX	AL	CRES
					KRJ4	.2515	.3760	.3860
KRJ5	.3140	.4386	.4468	.4568	008	018	.008	.022
KRJ6	.3765	.5012	.5112	.5212	008	022	.009	.025
KRJ7	.4390	.5638	.5738	.5838	008	028	.010	.028
KRJ8	.5015	.6265	.6365	.6465	008	028	.011	.031
KRJ9	.5640	.6892	.6992	.7092	008	036	.013	.036
KRJ10	.6265	.8142	.8242	.8342	008	044	.022	.061
KRJ11	.6890	.8767	.8867	.8967	008	052	.023	.064
KRJ12	.7515	.9393	.9493	.9593	008	052	.025	.070
KRJ14	.8765	1.0645	1.0745	1.0845	008	052	.029	.080
KRJ16	1.0015	1.1898	1.1998	1.2098	008	060	.033	.091
KRJ18	1.1265	1.3148	1.3248	1.3348	010	060	.037	.101
KRJ20	1.2515	1.4398	1.4498	1.4598	012	068	.040	.111
KRJ22	1.3765	1.5648	1.5748	1.5848	012	068	.044	.122
KRJ24	1.5015	1.7523	1.7623	1.7723	012	088	.065	.179
KRJ26	1.6265	1.8773	1.8873	1.8973	016	096	.070	.193
KRJ28	1.7515	2.0023	2.0123	2.0223	016	096	.075	.207
KRJ32	2.0015	2.2523	2.2623	2.2723	016	096	.085	.234

LENGTH SUFFIX			
CODE	LENGTH +.000 -.010	CODE	LENGTH +.000 -.010
-008	.250	-048	1.500
-009	.281	-050	1.562
-010	.312	-052	1.625
-011	.344	-054	1.687
-012	.375	-056	1.750
-014	.437	-058	1.812
-016	.500	-060	1.875
-018	.562	-062	1.937
-020	.625	-064	2.000
-022	.687	-066	2.062
-024	.750	-068	2.125
-026	.812	-070	2.187
-028	.875	-072	2.250
-030	.937	-074	2.312
-032	1.000	-076	2.375
-034	1.062	-078	2.437
-036	1.125	-080	2.500
-038	1.187	-082	2.562
-040	1.250	-084	2.625
-042	1.312	-086	2.687
-044	1.375	-088	2.750
-046	1.437	-096	3.000

PART NUMBER EXAMPLE:

**KRJ 8 - S B C - 032 - L I** (ADD "T" FOR .010 OR "U" FOR .020 OVERSIZE DIA "D")

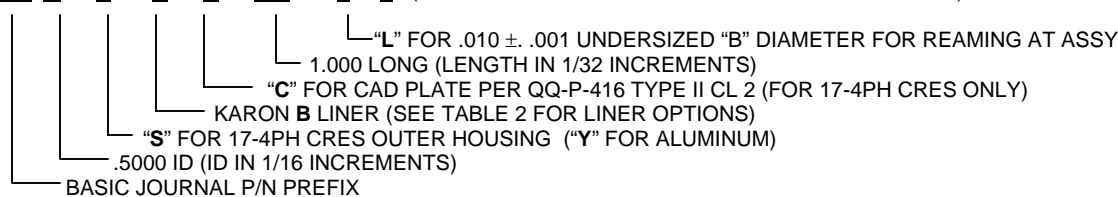

NOTE 1:

TOLERANCE, 17-4PH = +.0000, -.0005  
ALUMINUM, ± .0005

# KARON Lined Journal Bearings

# KRJ-U(D) Series – Sleeve, Flanged, Lined Bore, (Optional Lined Flange)

Qualified to SAE AS81934/2 with Karon B and Mil-B-8943 with Karon V, M, and RP

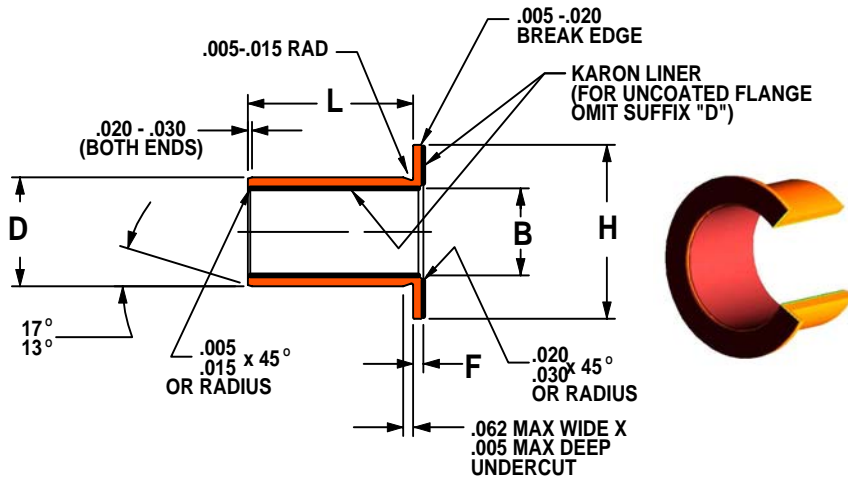

BEARING MATERIALS				
	MATERIAL	CONDITION	SURFACE FINISH	P/N SYMBOL
OUTER HOUSING	AMS 5643 17-4PH CRES	H1150	PASSIVATE PER QQ-P-35 OR CAD PLATE PER QQ-P-416	S
	QQ-A-200/3 OR QQ-A-225/8 2024 ALUMINUM	T851/T8511	ANODIZE PER MIL-A- 8625 TYPE I OR 11 OR CHEM FILM PER MIL-C-5541	Y
LINER	KARON	N/A	N/A	SEE TABLE 2 FOR LINER OPTIONS

M81934/2  BEARING NUMBER	B	D	H	F	T .010 O'SIZE DIA D See NOTE 1	U .020 O'SIZE DIA D See NOTE 1	L		FLANGE WEIGHT LBS/INCH (REF) NOTE 2	
	BORE DIA. + .0000 - .0010	OUTER DIA. See NOTE 1	FLANGE DIA. + .000 - .020	FLANGE WIDTH + .000 - .005			Mil Spec Length Limits (Suggested)		AL	CRES
							MIN	MAX		
KRJ4-UD	.2515	.3760	.750		.3860	.3960	.008	.014	.003	.007
KRJ5-UD	.3140	.4386	.812		.4468	.4568	.008	.018	.003	.007
KRJ6-UD	.3765	.5012	.875		.5112	.5212	.008	.022	.003	.007
KRJ7-UD	.4390	.5638	.937		.5738	.5838	.008	.028	.013	.008
KRJ8-UD	.5015	.6265	1.000		.6365	.6465	.008	.028	.004	.010
KRJ9-UD	.5640	.6892	1.125	.0625	.6992	.7092	.008	.036	.004	.011
KRJ10-UD	.6265	.8142	1.250		.8242	.8342	.008	.044	.005	.014
KRJ11-UD	.6890	.8767	1.375		.8867	.8967	.008	.052	.007	.020
KRJ12-UD	.7515	.9393	1.500		.9493	.9593	.008	.052	.009	.023
KRJ14-UD	.8765	1.0645	1.625		1.0745	1.0845	.008	.052	.009	.025
KRJ16-UD	1.0015	1.1898	1.750		1.1998	1.2098	.008	.060	.010	.027
KRJ18-UD	1.1265	1.3148	1.875		1.3248	1.3348	.010	.060	.014	.041
KRJ20-UD	1.2515	1.4398	2.000		1.4498	1.4598	.012	.068	.018	.050
KRJ22-UD	1.3765	1.5648	2.125		1.5748	1.5848	.012	.068	.019	.053
KRJ24-UD	1.5015	1.7523	2.250	.0937	1.7623	1.7723	.012	.088	.019	.054
KRJ26-UD	1.6265	1.8773	2.375		1.8873	1.8973	.016	.096	.020	.056
KRJ28-UD	1.7515	2.0023	2.500		2.0123	2.0223	.016	.096	.023	.064
KRJ32-UD	2.0015	2.2523	2.750		2.2623	2.2723	.016	.096	.026	.072

LENGTH SUFFIX			
CODE	LENGTH + .000 - .010	CODE	LENGTH + .000 - .010
-008	.250	-048	1.500
-009	.281	-050	1.562
-010	.312	-052	1.625
-011	.344	-054	1.687
-012	.375	-056	1.750
-014	.437	-058	1.812
-016	.500	-060	1.875
-018	.562	-062	1.937
-020	.625	-064	2.000
-022	.687	-066	2.062
-024	.750	-068	2.125
-026	.812	-070	2.187
-028	.875	-072	2.250
-030	.937	-074	2.312
-032	1.000	-076	2.375
-034	1.062	-078	2.437
-036	1.125	-080	2.500
-038	1.187	-082	2.562
-040	1.250	-084	2.625
-042	1.312	-086	2.687
-044	1.375	-088	2.750
-046	1.437	-096	3.000

PART NUMBER EXAMPLE:

**KRJ 8 - U D S B C - 032 - L I** ( ADD "T" FOR .010 OR "U" FOR .020 OVERSIZE DIA "D" )

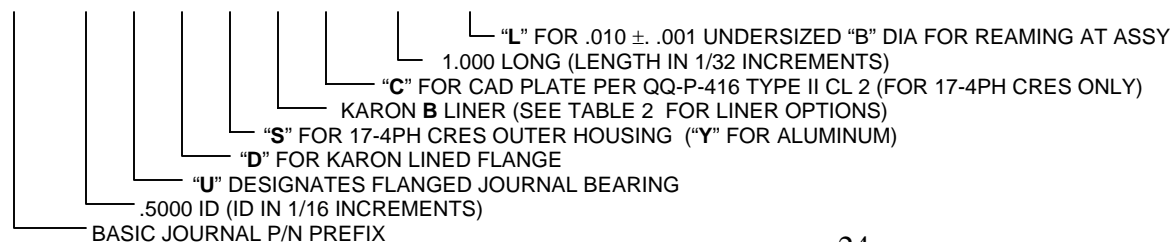

**NOTES:**

1. TOLERANCE, 17-4PH = +.0000, -.0005 ALUMINUM, ± .0005
2. ADD FLANGE WEIGHT TO THE SLEEVE WEIGHT SHOWN FOR THE EQUIVALENT DIAMETER "KRJ" NON FLANGED BEARING

# KARON Lined Spherical Bearings

**KR-CN Series – Narrow, Chamfered Outer Race**  
**-54° C to +163° C**  
**KR3 to KR16 Qualified to SAE AS81820 with Karon B Liner**

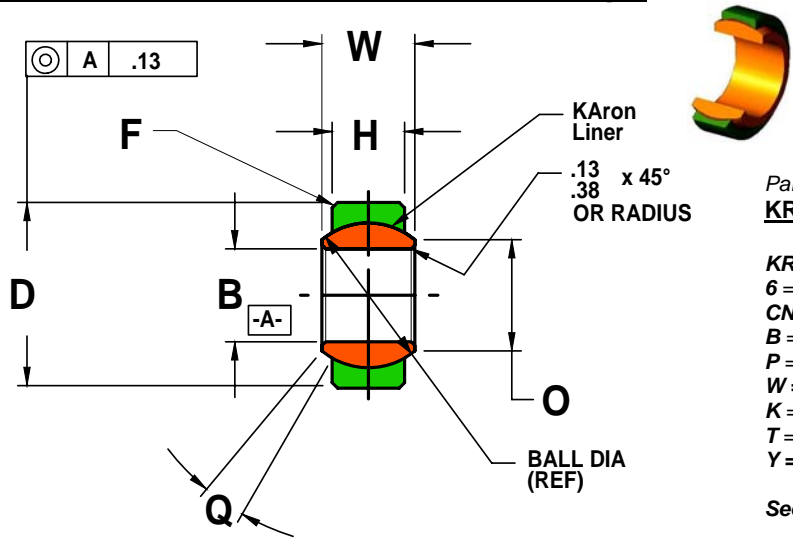

Part Number Example:  
**KR 6 - CN B P K T**

**KR** = Basic Karon Spherical Bearing Prefix  
**6** = 9.5250 mm ID  
**CN** = Narrow Chamfered Outer Race  
**B** = Karon B liner (See Table 2 for liner Options)  
**P** = Cadmium Plated OD per QQ-P-416 Option  
**W** = Chrome Plated Ball OD Option  
**K** = Low Breakaway Torque Option  
**T** = .010 Oversize OD Option  
**Y** = PH13-8Mo Ball option (440C no letter)

See KR-CN/4 Series for Lined Bore

Bearing Size	Nominal Bore	T	U
		.254 OD Oversize +0.000 -0.0127	.508 OD Oversize +0.000 -0.0127
-3	4.8260	14.5415	14.7955
-4	6.3500	16.9215	17.1755
-5,5A	7.9375	19.3040	19.5580
-6	9.5250	20.8915	21.1455
-7	11.1125	23.2715	23.5255
-8	12.7000	25.6540	25.9080
-9	14.2875	28.0340	28.2880
-10	15.8750	30.4165	30.6705
-12	19.0500	36.7665	37.0205
-14	22.2250	39.9415	40.1955
-16	25.4000	44.7040	44.9580
-20	31.7500	51.0540	51.3080

AS14104/ MS14104	<b>METRIC - All Dimensions in Millimeters</b>											
	B	D	W	H	O	F	Q°					
BEARING NUMBERS	BORE DIA	OUTSIDE DIA	BALL WIDTH	RACE WIDTH	SHOULDER DIA (MIN)	BALL DIA (REF)	CHAMFER X 45°	RADIAL DYNAMIC LOAD RATING (KN) See Note 1	APPROX. MISALIGNMENT (°)	RADIAL STATIC LIMIT LOAD (KN) See Note 1	AXIAL STATIC LIMIT LOAD (KN) See Note 1	APPROX WEIGHT (KG)
	+0.000 -0.013	+0.000 -0.013	+0.000 -0.051	+1.127 -1.127								
KR3-CN	4.826	14.288	7.137	5.537	7.442	10.312		6.7	10	17.7	0.7	0.009
KR4-CN	6.350	16.668	8.712	6.350	9.246	12.700	.254/.508	14.8	10	26.9	1.9	0.009
KR5-CN	7.938	19.050	9.525	7.137	10.643	14.275		24.3	10	38.9	3.1	0.014
KR6-CN	9.525	20.638	10.312	7.925	12.065	15.875		29.4	9	46.9	4.9	0.018
KR7-CN	11.113	23.018	11.100	8.712	13.462	17.450		35.8	8	58.7	6.2	0.023
KR8-CN	12.700	25.400	12.700	9.906	15.240	19.837	.508/.762	46.3	8	79.6	9.3	0.032
KR9-CN	14.288	27.780	14.275	11.100	17.018	22.225		57.8	8	103.2	16.4	0.041
KR10-CN	15.875	30.163	15.875	12.700	18.771	24.587		73.2	8	135.7	21.0	0.054
KR12-CN	19.050	36.513	19.050	15.062	23.368	30.150		105.0	8	206.4	30.0	0.095
KR14-CN	22.225	39.688	22.225	17.856	24.892	33.325	.762/1.016	134.6	8	276.7	41.6	0.122
KR16-CN	25.400	44.450	25.400	20.244	28.397	38.100		169.0	9	365.7	54.1	0.177
KR20-CN	31.750	50.800	27.762	23.927	35.712	45.237		231.8	6	480.4	69.0	0.240

Bearing Size	No-Load Rotational Breakaway Torque N-m		Bearing Clearances "K" Type Only	
	Standard	"K" Type	Radial (Max.) (mm)	Axial (Max) (mm)
3 and 4	0.03 to 0.56	0 to 0.090	0.018	0.071
5 thru 12	0.03 to 0.90	0 to 0.112	0.018	0.071
14 thru 20	0.03 to 1.35	0 to 0.225	0.025	0.102

**Bearing Materials:**

**Liner** = See Table 2 for liner options  
**Outer Race** = 17-4PH (AMS5643) H1150 Cond.  
**Ball** = 440C (AMS5630) HRC 55/62 or PH13-8Mo (AMS5629) H1000 Cond. Passivate PH13-8Mo per QQ-P-35,  
 Chrome option per QQ-C-320 Class 2 (0.005-0.013 thick).

**Note 1: Load Ratings Shown are with Karon B Liner System**

# KARON Lined Spherical Bearings

**KR-CNG Series – Narrow, Grooved Outer Race**  
**-54° C to +163° C**  
**KR3 to KR16 Qualified to SAE AS81820 with Karon B Liner**

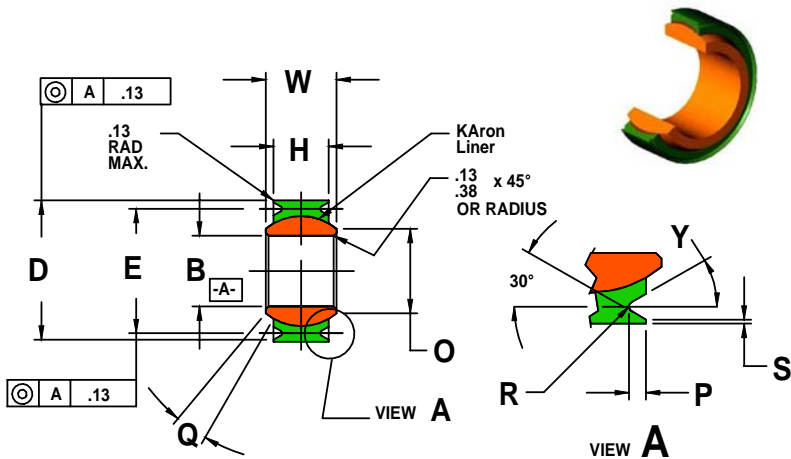

Part Number Example:

**KR 6- CN G B P K I**

- KR** = Karon Spherical Bearing Prefix
- 6** = 9.525 mm
- CN** = Narrow Outer Race
- G** = Grooved Outer Race
- B** = Karon B liner (See Table 2 for liner options)
- P** = Cadmium Plated OD per QQ-P- 416 Option
- W** = Chrome Plated Ball OD Option
- K** = Low Breakaway Torque Option
- T** = .010 Oversize OD Option
- Y** = PH13-8Mo Ball option (440C no letter)

See KR-CNG/1 Series for Lined Bore

Bearing Size	Nominal Bore	T	U
		.254 OD Oversize +0.000 -0.0127	.508 OD Oversize +0.000 -0.0127
-3	4.826	14.542	14.796
-4	6.350	16.921	17.175
-5,5A	7.938	19.304	19.558
-6	9.525	20.892	21.146
-7	11.113	23.271	23.525
-8	12.700	25.654	25.908
-9	14.288	28.034	28.288
-10	15.875	30.417	30.671
-12	19.050	36.767	37.021
-14	22.225	39.942	40.196
-16	25.400	44.704	44.958
-20	31.750	51.054	51.308

AS14101/ MS14101	<b>METRIC - All Dimensions in Millimeters</b>											
	B	D	W	H	O		E		Q°			
BEARING NUMBERS	BORE DIA	OUTSIDE DIA	BALL WIDTH	RACE WIDTH	SHOULDER DIA (MIN)	BALL DIA (REF)	GROOVE DIA +.000 -.203	RADIAL DYNAMIC LOAD RATING (KN) See Note 1	APPROX. MISALIGNMENT (°)	RADIAL STATIC LIMIT LOAD (KN) See Note 1	AXIAL STATIC LIMIT LOAD (KN) See Note 1	APPROX WEIGHT (KG)
	+0.000 -0.013	+0.000 -0.013	+0.000 -0.051	+0.127 -0.127								
KR3-CNG	4.826	14.288	7.137	5.537	7.442	10.312	12.700	6.67	10	17.68	0.67	0.009
KR4-CNG	6.350	16.667	8.712	6.350	9.246	12.700	15.088	14.77	10	26.87	1.91	0.009
KR5-CNG	7.938	19.050	9.525	7.137	10.643	14.275	16.510	24.29	10	38.92	3.11	0.014
KR5A-CNG	7.938	19.050	9.525	7.137	10.643	14.275	16.764	24.29	10	38.92	3.11	0.014
KR6-CNG	9.525	20.638	10.312	7.925	12.065	15.875	18.085	29.36	9	46.89	4.89	0.018
KR7-CNG	11.113	23.017	11.100	8.712	13.462	17.450	20.472	35.81	8	58.72	6.23	0.023
KR8-CNG	12.700	25.400	12.700	9.906	15.240	19.837	22.250	46.26	8	79.63	9.34	0.032
KR9-CNG	14.288	27.780	14.275	11.100	17.018	22.225	24.638	57.83	8	103.20	16.37	0.041
KR10-CNG	15.875	30.163	15.875	12.700	18.771	24.587	27.000	73.18	8	135.68	21.00	0.054
KR12-CNG	19.050	36.513	19.050	15.062	23.368	30.150	33.350	104.98	8	206.41	30.03	0.095
KR14-CNG	22.225	39.688	22.225	17.856	24.892	33.325	36.525	134.56	8	276.69	41.59	0.122
KR16-CNG	25.400	44.450	25.400	20.244	28.397	38.100	41.300	169.04	9	365.66	54.09	0.177
KR20-CNG	31.750	50.800	27.762	23.927	35.712	45.237	47.650	231.76	6	480.43	68.95	0.240

**Bearing Materials:**

**Liner** = See Table 2 for liner options  
**Outer Race** = 17-4PH (AMS5643) H1150 Cond.  
**Ball** = 440C (AMS5630) HRC 55/62 or PH13-8Mo (AMS5629) H1000 Cond. Passivate PH13-8Mo per QQ-P-35,  
 Chrome option per QQ-C-320 Class 2 (0.005-0.013 thick).

**Note 1: Load Ratings Shown are with Karon B Liner System**

Bearing Size	No-Load Rotational Breakaway Torque N-m		Bearing Clearances "K" Type Only	
			Radial (Max.) (mm)	Axial (Max) (mm)
	Standard	"K" Type		
3 and 4	0.03 to 0.56	0 to 0.090	0.018	0.071
5 thru 12	0.03 to 0.90	0 to 0.112	0.018	0.071
14 thru 20	0.03 to 1.35	0 to 0.225	0.025	0.102

Bearing Size	P (mm)	R (mm)	S (mm)	Y°
	+0.000 -0.254	+0.000 -0.127	Ref.	
3 and 4	0.635	0.254	0.254	20/31
5A	0.890	0.254	0.254	20/30
5 thru 7	0.890	0.430	0.508	30
8 thru 20	1.00	0.430	0.508	30

# KARON Lined Spherical Bearings

**KR-CW Series – Wide, Chamfered Outer Race**  
**-54° C to +163° C**  
**KR3 to KR16 Qualified to SAE AS81820 with Karon B Liner**

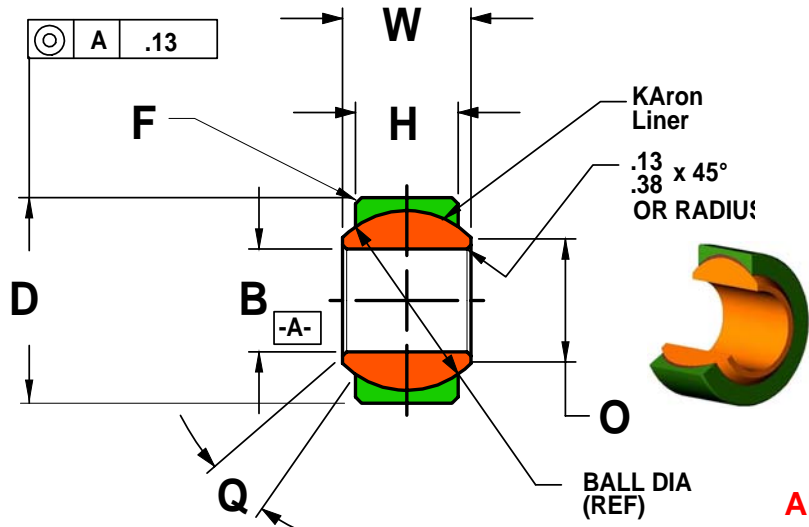

Part Number Example:  
**KR 6- CW B K P I**  
 KR = Karon Spherical Bearing Prefix  
 6 = 9.525 mm ID  
 CW = Chamfered Wide Outer Race  
 B = Karon B liner (See Table 2 for Liner Options)  
 P = Cadmium Plated OD per QQ-P-416 Option  
 W = Chrome Plated Ball OD Option  
 K = Low Breakaway Torque Option  
 T = .010 Oversize OD Option  
 Y = PH13-8Mo Ball option (440C no letter)  
 See KR-CW/2 for Lined Bore

Bearing Size	Nominal Bore	T	U
		.254 OD Oversize +.000 -.013	.508 OD Oversize +.000 -.013
-3	4.826	16.129	16.383
-4	6.350	16.129	16.383
-5	7.938	17.717	17.971
-6	9.525	20.892	21.146
-7	11.113	24.067	24.321
-8	12.700	25.654	25.908
-9	14.288	28.829	29.083
-10	15.875	30.417	30.671
-12	19.050	35.179	35.433
-14	22.225	41.529	41.783
-16	25.400	54.229	54.483
-20	31.750	60.579	60.833

**METRIC**  
 All Dimensions in Millimeters

AS14102/ MS14102	B	D	W	H	O	F	Q°					
BEARING NUMBERS	BORE DIA	OUTSIDE DIA	BALL WIDTH	RACE WIDTH	SHOULDER DIA (MIN)	BALL DIA (REF)	CHAMFER X 45°	RADIAL DYNAMIC LOAD RATING (KN) See Note 1	APPROX. MISALIGNMENT (°)	RADIAL STATIC LIMIT LOAD (KN) See Note 1	AXIAL STATIC LIMIT LOAD (KN) See Note 1	APPROX WEIGHT (KG)
	+0.000 -.013	+0.000 -.013	+0.000 -.051	+0.127 -.127								
KR3-CW	4.826	15.875	11.100	8.306	7.620	13.487		21.8	15	11.1	7.9	0.014
KR4-CW	6.350	15.875	11.100	8.306	7.620	13.487	.254/.508	21.8	15	24.5	7.9	0.014
KR5-CW	7.938	17.463	11.100	8.052	9.144	14.275		26.9	14	41.8	7.3	0.018
KR6-CW	9.525	20.638	12.700	10.312	11.836	17.450		37.0	8	60.9	11.7	0.027
KR7-CW	11.113	23.813	14.275	11.227	13.640	19.837		52.3	10	92.1	16.2	0.036
KR8-CW	12.700	25.400	15.875	12.827	15.418	22.225	.508/.762	66.5	9	95.2	22.1	0.045
KR9-CW	14.288	28.575	17.450	13.614	18.313	25.400		80.5	10	118.3	23.9	0.063
KR10-CW	15.875	30.163	19.050	14.402	18.974	26.975		90.1	12	129.0	27.3	0.073
KR12-CW	19.050	34.925	22.225	16.002	21.463	30.937		116.6	13	164.6	34.4	0.109
KR14-CW	22.225	41.275	22.225	19.177	25.273	34.925	.760/1.02	149.5	6	290.0	48.0	0.159
KR16-CW	25.400	53.975	34.925	25.527	32.233	47.625		250.2	12	462.6	85.9	0.440
KR20-CW	31.750	60.325	38.100	28.702	37.084	53.162		293.2	14	680.6	95.2	0.499

Bearing Size	No-Load Rotational Breakaway Torque N-m		Bearing Clearances "K" Type Only	
	Standard	"K" Type	Radial (Max.) (mm)	Axial (Max.) (mm)
3 and 4	0.03 to 0.56	0 to 0.090	0.018	0.071
5 thru 12	0.03 to 0.90	0 to 0.112	0.018	0.071
14 thru 20	0.03 to 1.35	0 to 0.225	0.025	0.102

**Bearing Materials:**  
**Liner** = See Table 2 for liner options  
**Outer Race** = 17-4PH (AMS5643) H1150 Cond.  
**Ball** = 440C (AMS5630) HRC 55/62 or PH13-8Mo (AMS5629) H1000 Cond. Passivate PH13-8Mo per QQ-P-35, Chrome option per QQ-C-320 Class 2 (0.005-0.013 thick).  
**Note 1: Load Ratings Shown are with Karon B Liner System**

# KARON Lined Spherical Bearings

**KR-CWG Series – Wide, Grooved Outer Race**  
**-54° C to +163° C**  
**KR3 to KR16 Qualified to SAE AS81820 with Karon B Liner**

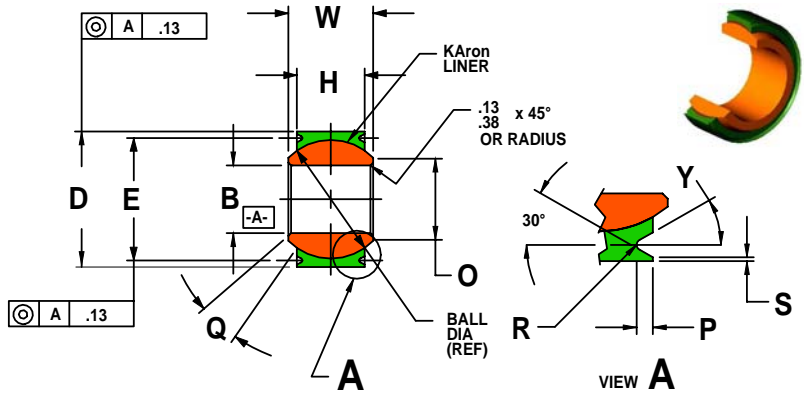

Part Number Example:  
**KR 6- CW G B K P T**

**KR** = Karon Spherical Bearing Prefix  
**6** = 9.525 mm ID  
**CW** = Chamfered Wide Outer Race  
**G** = Grooved Outer Race  
**B** = Karon B liner (See Table 2 for Liner Options)  
**P** = Cadmium Plated OD per QQ-P-416 Option  
**W** = Chrome Plated Ball OD Option  
**K** = Low Breakaway Torque Option  
**T** = .254 Oversize OD Option  
**Y** = PH13-8Mo Ball option (440C no letter)  
 See **KR-CWG/3** for Lined Bore

Bearing Size	Nominal Bore	T	U
		.254 OD Oversize	.508 OD Oversize
		+ .000	+ .000
		- .013	- .013
-3	4.826	16.129	16.383
-4	6.350	16.129	16.383
-5	7.938	17.717	17.971
-6	9.525	20.892	21.146
-7	11.113	24.067	24.321
-7A	11.113	23.271	23.525
-8	12.700	25.654	25.908
-9	14.288	28.829	29.083
-10	15.875	30.417	30.671
-12	19.050	35.179	35.497
-14	22.225	41.529	41.783
-16	25.400	54.229	54.483
-20	31.750	60.579	60.897

**METRIC**  
 All Dimensions in Millimeters

AS14103/ MS14103	B	D	W	H	O	E	Q°					
BEARING NUMBERS	BORE DIA	OUTSIDE DIA	BALL WIDTH	RACE WIDTH	SHOULDER DIA (MIN)	BALL DIA (REF)	GROOVE DIA + .000 - .127	RADIAL DYNAMIC LOAD RATING (KN)	APPROX. MISALIGNMENT (°)	RADIAL STATIC LIMIT LOAD (KN)	AXIAL STATIC LIMIT LOAD (KN)	APPROX WEIGHT (KG)
	+ .000 - .013	+ .000 - .013	+ .000 - .051	+ .127 - .127								
KR3-CWG	4.826	15.875	11.100	8.306	7.620	13.487	14.300	21.8	15	11.1	7.9	0.014
KR4-CWG	6.350	15.875	11.100	8.306	7.620	13.487	14.300	21.8	15	24.5	7.9	0.014
KR5-CWG	7.938	17.463	11.100	8.052	9.144	14.275	15.799	26.9	14	41.8	7.3	0.018
KR6-CWG	9.525	20.638	12.700	10.312	11.836	17.450	18.085	37.0	8	60.9	11.7	0.027
KR7-CWG	11.113	23.813	14.275	11.227	13.640	19.837	21.260	52.3	10	92.1	16.2	0.036
KR7A-CWG	11.113	23.017	14.275	11.227	13.640	19.837	20.472	52.3	10	92.1	16.2	0.036
KR8-CWG	12.700	25.400	15.875	12.827	15.418	22.225	22.860	66.5	9	95.2	22.1	0.045
KR9-CWG	14.288	28.575	17.450	13.614	18.313	25.400	26.035	80.5	10	118.3	23.9	0.063
KR10-CWG	15.875	30.163	19.050	14.402	18.974	26.975	27.610	90.1	12	129.0	27.3	0.073
KR12-CWG	19.050	34.925	22.225	16.002	21.463	30.937	31.775	116.5	13	164.6	34.4	0.109
KR14-CWG	22.225	41.275	22.225	19.177	25.273	34.925	38.125	149.5	6	290.0	48.0	0.159
KR16-CWG	25.400	53.975	34.925	25.527	32.233	47.625	50.825	250.2	12	462.6	85.9	0.440
KR20-CWG	31.750	60.325	38.100	28.702	37.084	53.162	57.175	293.1	14	680.6	95.2	0.499

Bearing Size	No-Load Rotational Breakaway Torque N-m		Bearing Clearances "K" Type Only	
	Standard	"K" Type	Radial (Max.) (mm)	Axial (Max.) (mm)
3 and 4	0.03 to 0.56	0 to 0.09	0.018	0.071
5 thru 12	0.03 to 0.90	0 to 0.11	0.018	0.071
14 thru 20	0.03 to 1.35	0 to 0.23	0.025	0.102

Bearing Size	P (mm)	R (mm)	S (mm)	Y°
	+ .000 - .254	+ .000 - .178	Ref.	.
3 and 5	.635	.305	.254	20/30
6 thru 10	.890	.430	.508	30
10 thru 2	1.400	.430	.508	30

**Bearing Materials:**  
**Liner** = See Table 2 for liner options  
**Outer Race** = 17-4PH (AMS5643) H1150 Cond.  
**Ball** = 440C (AMS5630) HRC 55/62 or PH13-8Mo (AMS5629) H1000 Cond. Passivate PH13-8Mo per QQ-P-35, Chrome option per QQ-C-320 Class 2 (0.005-0.013 thick).  
**Note 1: Load Ratings Shown are with Karon B Liner System**

# KARON Lined Spherical Bearings

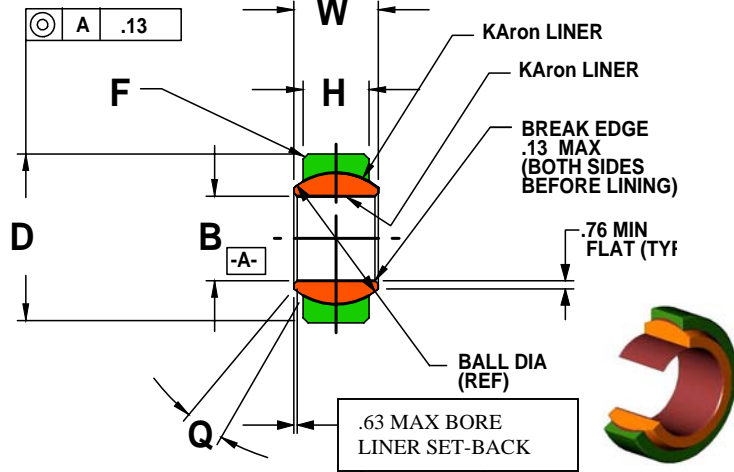

**KR-CN/4 Series – Narrow, Chamfered Outer Race**  
**Lined Bore, -54° C to +163° C**  
**KR4 to KR16 Qualified to SAE AS81820 with KArOn B Liner**

Part Number Example:

**KR 6 - CN /4 B K P I**

- KR** = KArOn Spherical Bearing Prefix
- 6** = 9.525 mm ID
- CN** = Narrow Outer Race
- /4** = KArOn Lined Bore (ID)
- B** = KArOn B liner (See Table 2 for Liner Options)
- P** = Cadmium Plated OD per QQ-P-416 Option
- W** = Chrome Plated Ball OD Option
- K** = Low Breakaway Torque Option
- T** = .254 Oversize OD Option
- Y** = PH13-8Mo Ball option (440C no letter)

Bearing Size	Maximum Bore	T	U
		.254 OD Oversize +0.000 -.013	.508 OD Oversize +0.000 -.013
-3	4.851	14.542	14.796
-4	6.375	16.921	17.175
-5	7.963	19.304	19.558
-6	9.550	20.892	21.146
-7	11.138	23.271	23.525
-8	12.725	25.654	25.908
-9	14.313	28.034	28.288
-10	15.900	30.417	30.671
-12	19.075	36.767	37.021
-14	22.250	39.942	40.196
-16	25.425	44.704	44.958
-20	31.775	51.054	51.308

**METRIC**  
**All Dimensions in Millimeters**

AS81820/4 M81820/4 (Ref)	B	D	W	H		F		Q°			
BEARING NUMBERS	BORE DIA	OUTSIDE DIA	BALL WIDTH	RACE WIDTH	BALL DIA (REF)	CHAMFER X 45°	RADIAL DYNAMIC LOAD RATING (KN) See Note 1	APPROX. MISALIGNMENT (°)	RADIAL STATIC LIMIT LOAD (KN) See Note 1	AXIAL STATIC LIMIT LOAD (KN) See Note 1	APPROX WEIGHT (KG)
	+0.000 -.025	+0.000 -.013	+0.000 -.051	+0.127 -.127							
KR3-CN/4	4.851	14.288	7.137	5.537	10.312		6.7	10	17.7	0.7	0.009
KR4-CN/4	6.375	16.667	8.712	6.350	12.700	.25/.51	11.8	10	24.7	1.9	0.009
KR5-CN/4	7.963	19.050	9.525	7.137	14.275		16.5	10	34.3	3.1	0.014
KR6-CN/4	9.550	20.638	10.312	7.925	15.875		21.8	9	45.4	4.9	0.018
KR7-CN/4	11.138	23.017	11.100	8.712	17.450		29.8	8	57.6	6.2	0.023
KR8-CN/4	12.725	25.400	12.700	9.906	19.837	.51/.76	36.7	8	76.7	9.3	0.032
KR9-CN/4	14.313	27.780	14.275	11.100	22.225		46.7	8	98.5	16.4	0.041
KR10-CN/4	15.900	30.163	15.875	12.700	24.587		58.9	8	123.2	21.0	0.054
KR12-CN/4	19.075	36.513	19.050	15.062	30.150		86.3	8	180.2	30.0	0.095
KR14-CN/4	22.250	39.688	22.225	17.856	33.325	.76/1.02	119.0	8	248.9	41.6	0.122
KR16-CN/4	25.425	44.450	25.400	20.244	38.100		156.8	9	328.3	54.1	0.177
KR20-CN/4	31.775	50.800	27.762	23.927	45.237		214.6	6	480.4	69.0	0.240

Bearing Size	No-Load Rotational Breakaway Torque N-m		Bearing Clearances "K" Type Only	
	Standard	"K" Type	Radial (Max.) (mm)	Axial (Max.) (mm)
3 and 4	0.11 to 0.56	0 to 0.056	0.018	0.071
5 thru 12	0.11 to 1.70	0 to 0.11	0.018	0.071
14 thru 20	0.11 to 2.82	0 to 0.22	0.025	0.101

**Bearing Materials:**

- Liner** = See Table 2 for liner options
- Outer Race** = 17-4PH (AMS5643) H1150 Cond.
- Ball** = 440C (AMS5630) HRC 55/62 or PH13-8Mo (AMS5629) H1000 Cond. Passivate PH13-8Mo per QQ-P-35, Chrome option per QQ-C-320 Class 2 (0.005-0.013 thick).
- Note 1:** Load Ratings Shown are with KArOn B Liner System

# KARON Lined Spherical Bearings

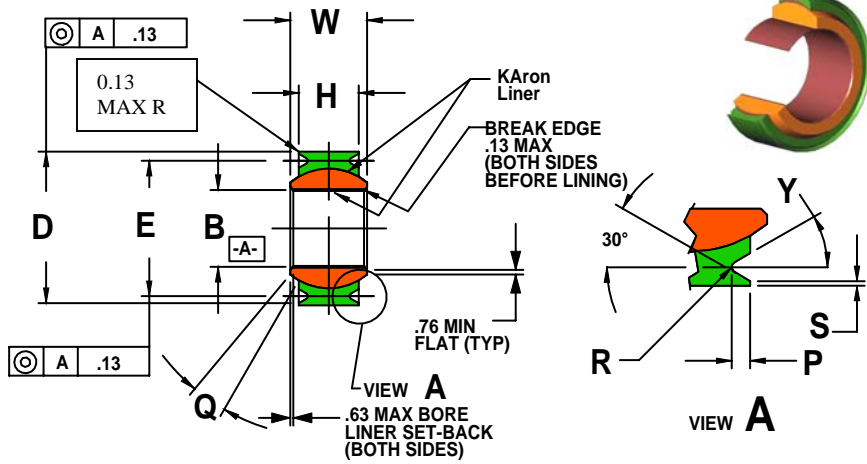

**KR-CNG/1 Series – Narrow, Grooved Outer Race**  
**Lined Bore, -54° C to +163° C**  
**KR4 to KR16 Qualified to SAE AS81820 with Karon B Liner**

Part Number Example:  
**KR 6- CN G /1 B K P T**  
 KR = Basic Karon Spherical Bearing  
 Prefix  
 6 = 9.525 mm ID  
 CN = Narrow Outer Race  
 G = Grooved Outer Race  
 /1 = Karon Lined Bore (ID)  
 B = Karon B liner (See Table 2 for Liner Options)  
 P = Cadmium Plated OD per QQ-P-416 Option  
 W = Chrome Plated Ball OD Option  
 K = Low Breakaway Torque Option  
 T = .254 Oversize OD Option  
 Y = PH13-8Mo Ball option (440C no letter)

Bearing Size	Nominal Bore	T	U
		.254 OD Oversize	.508 OD Oversize
		+0.000	+0.000
		-0.013	-0.013
-3	4.851	14.542	14.796
-4	6.375	16.921	17.175
-5	7.963	19.304	19.558
-6	9.550	20.892	21.146
-7	11.138	23.271	23.525
-8	12.725	25.654	25.908
-9	14.313	28.034	28.288
-10	15.824	30.417	30.671
-12	19.075	36.767	37.021
-14	22.250	39.942	40.196
-16	25.425	44.704	44.958
-20	31.775	51.054	51.308

**METRIC**  
 All Dimensions in Millimeters

AS81820/4 AS81820/1 (Ref)	B	D	W	H	E	Q°					
BEARING NUMBERS	BORE DIA	OUTSIDE DIA	BALL WIDTH	RACE WIDTH	BALL DIA (REF)	GROOVE DIA	RADIAL DYNAMIC LOAD RATING (KN)	APPROX. MISALIGNMENT (°)	RADIAL STATIC LIMIT LOAD (KN)	AXIAL STATIC LIMIT LOAD (KN)	APPROX WEIGHT (KG)
	+0.000 -0.025	+0.000 -0.013	+0.000 -0.051	+0.127 -0.127		+0.000 -0.020	See Note 1		See Note 1	See Note 1	
KR3-CNG/1	4.851	14.288	7.137	5.537	10.312	12.700	6.7	10	17.7	0.7	0.009
KR4-CNG/1	6.375	16.667	8.712	6.350	12.700	15.088	11.8	10	26.9	1.9	0.009
KR5-CNG/1	7.963	19.050	9.525	7.137	14.275	16.510	16.5	10	38.9	3.1	0.014
KR6-CNG/1	9.550	20.638	10.312	7.925	15.875	18.085	21.8	9	46.9	4.9	0.018
KR7-CNG/1	11.138	23.017	11.100	8.712	17.450	20.472	29.8	8	58.7	6.2	0.023
KR8-CNG/1	12.725	25.400	12.700	9.906	19.837	22.250	36.7	8	79.6	9.3	0.032
KR9-CNG/1	14.313	27.780	14.275	11.100	22.225	24.638	46.7	8	103.2	16.4	0.041
KR10-CNG/1	15.900	30.163	15.875	12.700	24.587	27.000	58.9	8	135.7	21.0	0.054
KR12-CNG/1	19.075	36.513	19.050	15.062	30.150	33.350	86.3	8	206.4	30.0	0.095
KR14-CNG/1	22.250	39.688	22.225	17.856	33.325	36.525	119.0	8	276.7	41.6	0.122
KR16-CNG/1	25.425	44.450	25.400	20.244	38.100	41.300	156.8	9	365.7	54.1	0.177
KR20-CNG/1	31.775	50.800	27.762	23.927	45.237	47.650	212.6	6	425.3	69.0	0.240

Bearing Size	No-Load Rotational Breakaway Torque N-m		Bearing Clearances "K" Type Only	
	Standard	"K" Type	Radial (Max.) (mm)	Axial (Max) (mm)
3 and 4	0.03 to 0.56	0 to 0.05	0.018	0.071
5 thru 12	0.03 to 0.90	0 to 0.11	0.018	0.071
14 thru 20	0.03 to 1.36	0 to 0.23	0.025	0.102

Bearing Size	P (mm)	R (mm)	S (mm)	Y°
	+0.000 -0.254	+0.000 -0.127	Ref.	
3 and 4	.635	.254	.254	20/3C
5 thru 7	.890	.430	.508	30
8 thru 20	1.400	.430	.508	30

**Bearing Materials:**

**Liner** = See Table 2 for liner options  
**Outer Race** = 17-4PH (AMS5643) H1150 Cond.  
**Ball** = 440C (AMS5630) HRC 55/62 or PH13-8Mo (AMS5629) H1000 Cond. Passivate PH13-8Mo per QQ-P-35, Chrome option per QQ-C-320 Class 2 (0.005-0.013 thick).  
**Note 1:** Load Ratings Shown are with Karon B Liner System

# KARON Lined Spherical Bearings

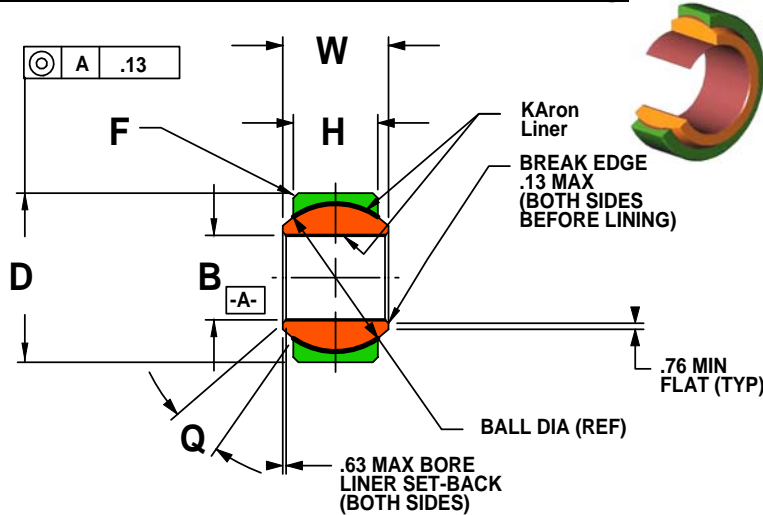

**KR-CW/2 Series – Wide, Chamfered Outer Race**  
**Lined Bore, -54° C to +163° C**  
**KR5 to KR16 Qualified to SAE AS81820 with Karon B Liner**

Part Number Example:

**KR 6- CW /2 B P K I**

**KR** = Basic Karon Spherical Bearing Prefix

**6** = 9.525 mm ID

**CW** = Wide Chamfered Outer Race

**/2** = Karon Lined Bore

**B** = Karon B liner (See Table 2 for Liner Options)

**P** = Cadmium Plated OD per QQ-P-416 Option

**W** = Chrome Plated Ball OD Option

**K** = Low Breakaway Torque Option

**T** = .010 Oversize OD Option

**Y** = PH13-8Mo Ball option (440C no letter)

Bearing Size	Maximum Bore	T	U
		.254 OD Oversize +.000 -.013	.508 OD Oversize +.000 -.013
-3	4.851	16.129	16.383
-4	6.375	16.129	16.383
-5	7.963	17.717	17.971
-6	9.550	20.892	21.146
-7	11.138	24.067	24.321
-8	12.725	25.654	25.908
-9	14.313	28.829	29.083
-10	15.900	30.417	30.671
-12	19.075	35.179	35.433
-14	22.250	41.529	41.783
-16	25.425	54.229	54.483
-20	31.775	60.579	60.833

## METRIC

All Dimensions in Millimeters

AS81820/2 M81820/2 (Ref)	B	D	W	H	F	Q°					
BEARING NUMBERS	BORE DIA	OUTSIDE DIA	BALL WIDTH	RACE WIDTH	BALL DIA (REF)	CHAMFER X 45°	RADIAL DYNAMIC LOAD RATING (KN) See Note 1	APPROX. MISALIGNMENT (°)	RADIAL STATIC LIMIT LOAD (KN) See Note 1	AXIAL STATIC LIMIT LOAD (KN) See Note 1	APPROX WEIGHT (KG)
	+0.0000 -0.0254	+0.000 -0.013	+0.000 -0.051	+0.127 -0.127							
KR3-CW/2	4.851	15.875	11.100	8.306	13.487		6.7	15	17.7	7.9	0.014
KR4-CW/2	6.375	15.875	11.100	8.306	13.487	.38/.63	11.8	15	24.7	7.9	0.014
KR5-CW/2	7.963	17.463	11.100	8.052	14.275		19.8	14	41.1	7.3	0.018
KR6-CW/2	9.550	20.638	12.700	10.312	17.450		27.6	8	57.8	11.7	0.027
KR7-CW/2	11.138	23.813	14.275	11.227	19.837		36.7	10	76.7	16.2	0.036
KR8-CW/2	12.725	25.400	15.875	12.827	22.225	.58/.76	47.2	9	95.2	22.1	0.045
KR9-CW/2	14.313	28.575	17.450	13.614	25.400		58.7	10	113.9	23.9	0.063
KR10-CW/2	15.900	30.163	19.050	14.402	26.975		67.4	12	129.0	27.3	0.073
KR12-CW/2	19.075	34.925	22.225	16.002	30.937		109.0	13	164.6	34.4	0.109
KR14-CW/2	22.250	41.275	22.225	19.177	34.925	.76/1.02	127.9	6	249.1	48.0	0.159
KR16-CW/2	25.425	53.975	34.925	25.527	47.625		219.3	12	459.5	85.9	0.440
KR20-CW/2	31.775	60.325	38.100	28.702	53.162		300.3	14	609.0	95.2	0.499

Bearing Size	No-Load Rotational Breakaway Torque N-m		Bearing Clearances "K" Type Only	
	Standard	"K" Type	Radial (Max.) (mm)	Axial (Max) (mm)
3 to 12	0.11 to 1.69	0 to 0.11	0.018	0.053
14 thru 20	0.11 to 2.82	0 to 0.23	0.025	0.076

### Bearing Materials:

**Liner** = See Table 2 for liner options

**Outer Race** = 17-4PH (AMS5643) H1150 Cond.

**Ball** = 440C (AMS5630) HRC 55/62 or PH13-8Mo

(AMS5629) H1000 Cond. Passivate PH13-8Mo per QQ-P-35,

Chrome option per QQ-C-320 Class 2 (0.005-0.013 thick).

**Note 1:** Load Ratings Shown are with Karon B Liner System

# KARON Lined Spherical Bearings



**KR-CWG/3 Series – Wide, Grooved Outer Race**  
**-54° C to +163° C**  
**KR5 to KR16 Qualified to SAE AS81820 with Karon B Liner**

Part Number Example:

**KR 6 - CW G /3 B K P T**

**KR** = Basic Karon Spherical Bearing  
 Prefix

**6** = 9.525 mm ID

**CW** = Chamfered Wide Outer Race

**G** = Grooved Outer Race

**/3** = Karon Lined Bore (ID)

**B** = Karon B liner (See Table 2 for Liner Options)

**P** = Cadmium Plated OD per QQ-P-416 Option

**W** = Chrome Plated Ball OD Option

**K** = Low Breakaway Torque Option

**T** = .010 Oversize OD Option

**Y** = PH13-8Mo Ball option (440C no letter)

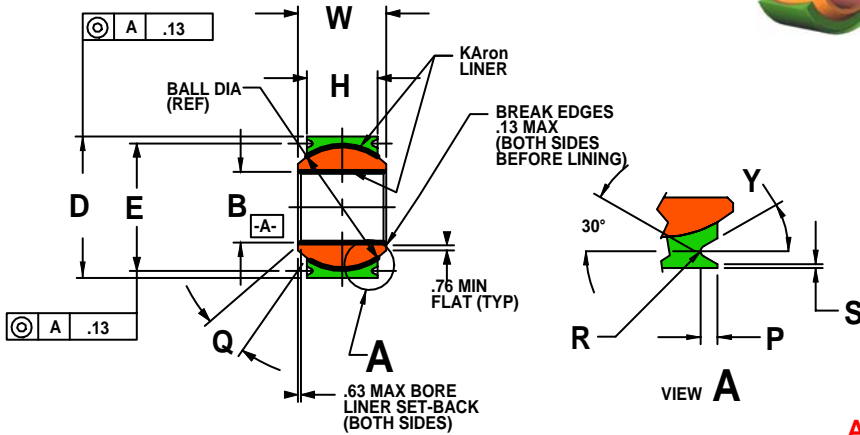

**METRIC**  
 All Dimensions in Millimeters

Bearing Size	Nominal Bore	T	U
		0.254 OD Oversize +0.000 -0.013	0.508 OD Oversize +0.000 -0.013
-4	6.375	16.129	16.383
-5	7.963	17.717	17.971
-6	9.550	20.892	21.146
-7	11.138	24.067	24.321
-7A	11.138	23.271	23.525
-8	12.725	25.654	25.908
-9	14.313	28.829	29.083
-10	15.824	30.417	30.671
-12	19.075	35.179	35.497
-14	22.250	41.529	41.783
-16	25.425	54.229	54.483
-20	31.775	60.579	60.897

AS81820/3 M81820/3 (Ref)	B	D	W	H		E		Q°			
BEARING NUMBERS	BORE DIA	OUTSIDE DIA	BALL WIDTH	RACE WIDTH	BALL DIA (REF)	GROOVE DIA +.000 -.020	RADIAL DYNAMIC LOAD RATING (KN) See Note 1	APPROX. MISALIGNMENT (°)	RADIAL STATIC LIMIT LOAD (KN) See Note 1	AXIAL STATIC LIMIT LOAD (KN) See Note 1	APPROX WEIGHT (KG)
	+0.000 -0.025	+0.000 -0.013	+0.000 -0.051	+0.127 -0.127							
KR3-CWG/3	4.851	15.875	11.100	8.306	13.487	14.300	6.7	15	17.7	7.9	0.014
KR4-CWG/3	6.375	15.875	11.100	8.306	13.487	14.300	11.8	15	31.6	7.9	0.014
KR5-CWG/3	7.963	17.463	11.100	8.052	14.275	15.799	19.8	14	41.4	7.3	0.018
KR6-CWG/3	9.550	20.638	12.700	10.312	17.450	18.085	27.6	8	57.8	11.7	0.027
KR7-CWG/3	11.138	23.813	14.275	11.227	19.837	21.260	36.7	10	77.0	16.2	0.036
KR7A-CWG/3	11.138	23.017	14.275	11.227	19.837	20.472	36.7	10	77.0	16.2	0.036
KR8-CWG/3	12.725	25.400	15.875	12.827	22.225	22.860	46.7	9	95.2	22.1	0.045
KR9-CWG/3	14.313	28.575	17.450	13.614	25.400	26.035	58.7	10	117.9	23.9	0.063
KR10-CWG/3	15.900	30.163	19.050	14.402	26.975	27.610	71.8	12	129.0	27.3	0.073
KR12-CWG/3	19.075	34.925	22.225	16.002	30.937	31.775	109.0	13	164.6	34.4	0.109
KR14-CWG/3	22.250	41.275	22.225	19.177	34.925	38.125	114.5	6	249.1	48.0	0.159
KR16-CWG/3	25.425	53.975	34.925	25.527	47.625	50.825	219.3	12	458.2	85.9	0.440
KR20-CWG/3	31.775	60.325	38.100	28.702	53.162	57.175	300.27	14	625.44	95.20	0.499

Bearing Size	No-Load Rotational Breakaway Torque N-m		Bearing Clearances "K" Type Only	
	Standard	"K" Type	Radial (Max.) (mm)	Axial (Max) (mm)
3 thru 12	0.11 to 1.69	0 to 0.11	0.018	0.051
14 thru 20	0.03 to 1.36	0 to 0.23	0.025	0.076

Bearing Size	P (mm)	R (mm)	S (mm)	Y°
	+0.000 -.254	+0.000 -.127	Ref.	
3 and 4	.025	.010	.254	20/30
5	.035	.017	.508	30
6 thru 20	.055	.017	.508	30

**Bearing Materials:**

**Liner** = See Table 2 for liner options

**Outer Race** = 17-4PH (AMS5643) H1150 Cond.

**Ball** = 440C (AMS5630) HRC 55/62 or PH13-8Mo (AMS5629) H1000 Cond. Passivate PH13-8Mo per QQ-P-35, Chrome option per QQ-C-320 Class 2 (0.005-0.013 thick).

**Note 1:** Load Ratings Shown are with Karon B Liner System

# KARON Lined Spherical Bearings

## KR-CE Series – Extended Inner Race, High Misalignment, Chamfered Outer Race

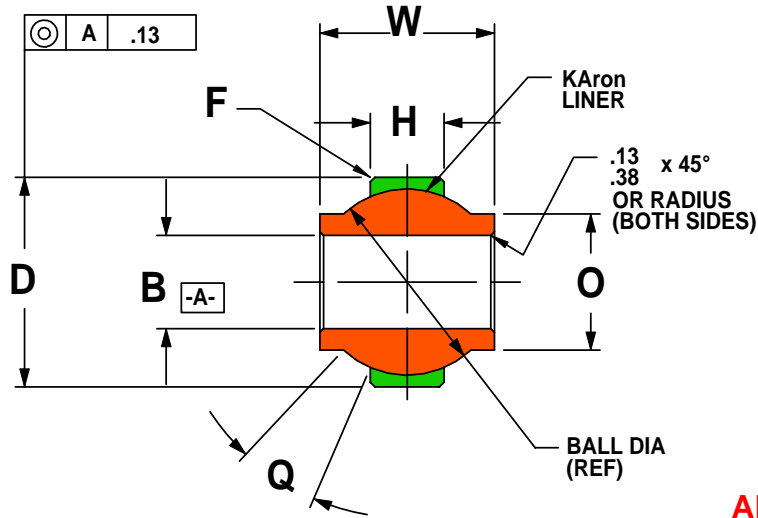

Part Number Example:

**KR 6- CE B P**

**KR** = Basic Karon Spherical Bearing Prefix  
**6** = 9.525 mm ID (ID in 1/16 inch increments)  
**CE** = Extended Inner Race (Ball) Width, Chamfered Outer Race  
**B** = Karon B liner (See Table 2 for Liner Options)  
**P** = Cadmium Plated OD per QQ-P-416 Option

**METRIC**  
 All Dimensions in Millimeters

BEARING NUMBERS	B	D	W	H	O	BALL DIA (REF)	F	See Note 1	Q°	See Note 1	See Note 1	APPROX WEIGHT (KG)
	BORE DIA +0.000 -0.013	OUTSIDE DIA +0.000 -0.013	BALL WIDTH +0.000 -0.051	RACE WIDTH +0.127 -0.127	SHOULDER DIA (MIN)		CHAMFER x 45°	RADIAL DYNAMIC LOAD RATING (KN)	APPROX. MISALIGNMENT (°)	RADIAL STATIC LIMIT LOAD (KN)	AXIAL STATIC LIMIT LOAD (KN)	
KR3-CE	4.826	14.288	12.700	5.207	8.103	11.100		12.1	15	16.6	1.7	0.014
KR4-CE	6.350	18.796	15.062	6.477	9.906	15.062	0.25/0.51	19.7	25	32.9	2.5	0.018
KR5-CE	7.938	17.463	15.875	6.477	10.617	15.062		19.7	20	32.9	2.5	0.018
KR6-CE	9.525	23.012	20.650	8.763	13.005	19.837		33.6	22	58.7	6.1	0.027
KR8-CE	12.700	28.575	23.800	10.058	18.542	25.400	0.51/0.38	47.6	20	97.0	9.8	0.073
KR10-CE	15.875	34.925	30.480	14.402	21.742	30.963		89.4	20	174.4	33.8	0.113
KR12-CE	19.050	39.688	32.512	15.748	24.638	34.925	0.38.1.02	101.4	20	209.1	46.3	0.204
KR16-CE	25.400	53.975	47.625	21.209	32.461	47.625		165.0	22	383.5	62.3	0.363

Bearing Size	No-Load Breakaway Torque (N-m)
3 & 4	0 to 0.56
5 thru 12	0 to 1.69
16	0 to 2.71

### Bearing Materials:

**Liner** = See Table 2 for Liner Options

**Outer Race** = 17-4PH (AMS 5643) Condition H1150

**Ball** = 440C (AMS 5630) Rc 55 Minimum

**Note 1: Load Ratings Shown are with Karon B Liner System**

# KARON Lined Spherical Bearings

# KR-CEG Series – Extended Inner Race, High Misalignment, Grooved Outer Race

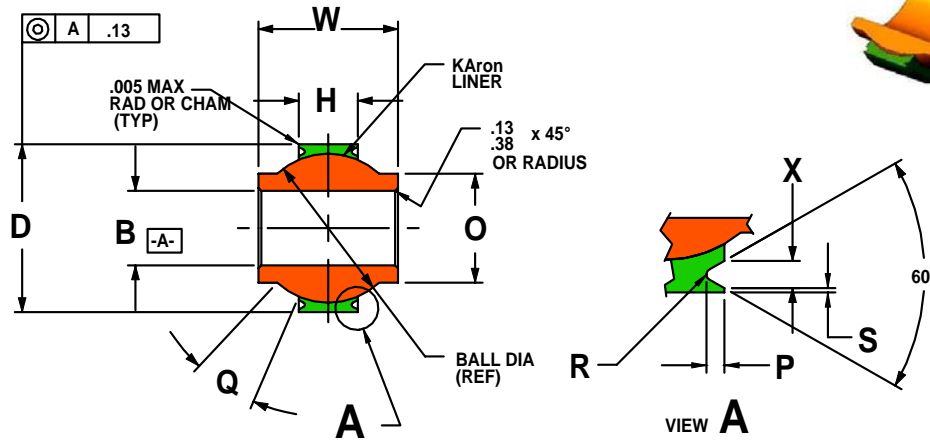

Part Number Example:  
**KR 6 - CE G B P**

**KR** = Basic Karon Spherical Bearing Prefix  
**6** = 9.525 MM ID (ID in 1/16 inch increments)  
**CE** = Extended Inner Race (Ball) Width  
**G** = Grooved Outer Race  
**B** = Karon B liner (See Table 2 for Liner Options)  
**P** = Cadmium Plated OD per QQ-P-416 Option

**METRIC**  
 All Dimensions in Millimeters

BEARING NUMBERS	B	D	W	H	O	BALL DIA (REF)	See Note 1	Q°	See Note 1	See Note 1	APPROX WEIGHT (KG)
	BORE DIA	OUTSIDE DIA	BALL WIDTH	RACE WIDTH	SHOULDER DIA (MIN)		RADIAL DYNAMIC LOAD RATING (KN)	APPROX. MISALIGNMENT (°)	RADIAL STATIC LIMIT LOAD (KN)	AXIAL STATIC LIMIT LOAD (KN)	
KR3-CEG	4.826	14.288	12.700	5.207	8.103	11.100	12.1	15	16.6	1.7	0.014
KR4-CEG	6.350	18.796	15.062	6.477	9.906	15.062	19.7	25	32.9	2.5	0.018
KR5-CEG	7.938	17.463	15.875	6.477	10.617	15.062	19.7	20	32.9	2.5	0.018
KR6-CEG	9.525	23.012	20.650	8.763	13.005	19.837	33.6	22	58.7	6.1	0.027
KR8-CEG	12.700	28.575	23.800	10.058	18.542	25.400	47.6	20	97.0	9.8	0.073
KR10-CEG	15.875	34.925	30.480	14.402	21.742	30.963	89.4	20	174.4	33.8	0.113
KR12-CEG	19.050	39.688	32.512	15.748	24.638	34.925	101.4	20	209.1	46.3	0.204
KR16-CEG	25.400	53.975	47.625	21.209	32.461	47.625	165.0	22	383.5	62.3	0.363

Bearing Size	P	R	S	X
	+0.000 -.381	+0.000 -.254	+0.000 -.254	+0.000 -.254
3 and 8	.762	.381	.508	1.143
10 thru 12	1.016	.508	.762	1.397
16	1.524	.508	.762	2.032

Bearing Size	No-Load Breakaway Torque (N-m)
3 & 4	0 to 0.57
5 thru 12	0 to 1.36
16	0 to 2.71

### Bearing Materials:

**Liner** = See Table 2 for Liner Options  
**Outer Race** = 17-4PH (AMS 5643) Condition H1150  
**Ball** = 440C (AMS 5630) Rc 55 Minimum

**Note 1:** Load Ratings Shown are with Karon B Liner System

# KARON Lined Spherical Bearings

## KR-C Series – Spherical Bearing, Miniature

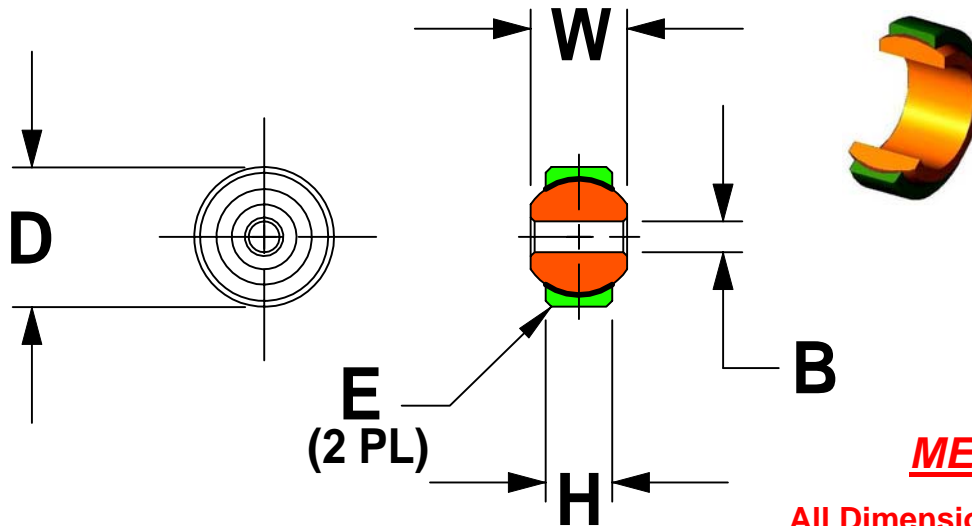

PART NUMBER EXAMPLE:

**KR 094 - C B**

**KR** = BASIC KARON PART NUMBER PREFIX  
**094** = 2.388 mm ID (BORE IN 0.001 INCH INCREMENTS)  
**C** = MINIATURE SPHERICAL BEARING CARTRIDGE  
**B** = KARON B LINER, SEE TABLE 2 FOR LINER OPTIONS

**METRIC**

All Dimensions in Millimeters

KR( ) C SERIES	B	D	W	H	E	SUGGESTED MATING HOUSING BORE SIZE	ULT. STATIC LOAD (KN) SEE NOTES 1 & 2
BEARING NUMBER	BORE DIA +.000 -.013	OUTER RACE DIA +.000 -.013	BALL WIDTH +.000 -.127	BODY WIDTH +.127 -.000	CHAMFER X 45° +.254 -.000		
<b>KR088-C</b>	2.235	6.350	3.175	2.540	0.254	6.350	2.235
<b>KR094-C</b>	2.383	7.142	3.937	3.048	0.254	7.142	2.383
<b>KR125-C</b>	3.175	9.195	6.350	4.369	0.254	9.195	3.175
<b>KR156-C</b>	3.962	11.905	7.137	4.750	0.254	11.905	3.962

	BALL	OUTER RACE	LINER
<b>MATERIAL</b>	AMS 5630 (440C)	AMS 5643 (17-4PH)	<b>KARON</b>
<b>HARDNESS</b>	Rc 55 MIN	Rc 28 MIN	SEE TABLE 2 FOR LINER OPTIONS

### NOTES

1. Load ratings shown are based on Karon B liner system
2. Loads shown are based on bearing components only, bolt/pin shear is not considered.
3. No load rotational breakaway torque = 0.11 N-m maximum

# KARON Lined Rod End Bearings

## METRIC

# KR-F Series – Rod End, Female

Dimensionally Equivalent to Mil-B-81935/2

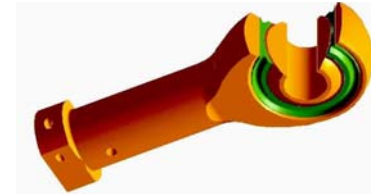
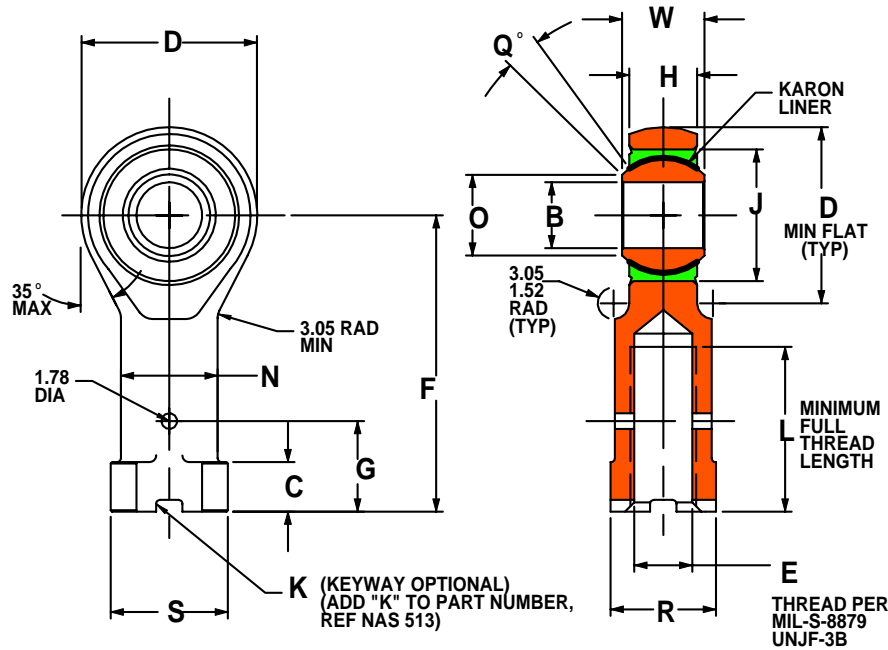

**METRIC**  
All Dimensions in Millimeters

PART NUMBER EXAMPLE:

**KR 6 - F S B L K**

- “K” FOR KEYWAY
- “L” FOR LEFT HAND THREAD
- KARON B LINER (SEE TABLE 2 FOR LINER OPTIONS)
- ROD END BODY MATERIAL, “S” OR “A”
- FEMALE ROD END BODY
- 9.525 mm DIA BORE, BORE SIZE IN 1/16 INCH INCREMENTS
- BASIC ROD END PART NUMBER PREFIX

M81935/2 SIZE	B	D	L	E	F	N	W	H	O	G	C	R	Q°	S	J	LOAD RATINGS (KN) See Note 1			WEIGHT MAX (KG)
BEARING NUMBER	BORE DIA +0.00 -0.013	ROD END DIA. +0.254 -0.254	THREAD LENGTH MIN	THREAD SIZE	BODY LENGTH +0.254 -0.254	SHANK DIA +0.254 -0.254	BALL WIDTH +0.001 -0.051	BODY WIDTH +0.127 -0.127	MIN BALL FLAT	+0.254 -0.254	+0.254 -1.575	+0.051 -0.254	MIN	REF DIA OR DISTANCE ACROSS CORNERS	MAX HOUSING ID	ULT. STATIC	FATIGUE	AXIAL PROOF	
KR3-F	4.826	20.472	19.050	5/16-24	34.925	10.719	11.100	8.560	7.620	9.525	4.775	11.100	15	12.700	15.875	10.5	6.5	4.4	0.036
KR4-F	6.350	20.472	19.050	5/16-24	37.313	10.719	11.100	8.560	7.620	9.525	4.775	11.100	15	12.700	15.875	21.6	10.6	4.4	0.038
KR5-F	7.938	22.860	22.225	3/8-24	41.275	12.319	11.100	8.306	9.144	11.100	6.350	12.700	14	14.732	17.463	31.9	13.4	4.9	0.046
KR6-F	9.525	26.035	25.400	3/8-24	46.025	13.894	12.700	10.566	11.836	11.100	6.350	14.275	8	16.764	20.638	38.0	15.9	7.4	0.073
KR7-F	11.113	29.210	28.575	7/16-20	50.800	15.494	14.275	11.481	13.640	12.700	6.350	15.875	10	18.288	23.017	53.4	21.4	8.2	0.096
KR8-F	12.700	33.960	31.750	1/2-20	57.150	18.669	15.875	13.081	15.418	14.275	6.350	19.050	9	22.606	25.400	86.7	36.7	9.1	0.147
KR10-F	15.875	38.735	34.925	5/8-18	63.500	21.844	19.050	14.656	18.974	17.450	9.525	22.225	12	25.908	30.163	97.4	40.8	10.8	0.218
KR12-F	19.050	45.085	41.275	3/4-16	73.025	25.019	22.225	16.256	21.463	20.625	9.525	25.400	13	29.464	34.925	130.3	51.6	12.5	0.305
KR14-F	22.225	51.435	47.625	7/8-14	85.725	28.194	22.225	19.431	25.273	23.800	12.700	28.575	6	33.020	41.275	153.5	58.3	14.8	0.435
KR16-F	25.400	70.485	53.975	1 1/4 -12	104.775	42.875	34.925	25.781	32.233	33.325	14.300	44.450	12	51.308	53.975	357.2	135.2	19.3	1.232

	BALL	RACE	LINER	BODY	DESIGNATION
MATERIAL	AMS 5630 (440C)	AMS 5643 (17-4PH)	KARON SEE TABLE 2 FOR LINER OPTIONS	AMS 5643 (17-4PH)	ADD SUFFIX S
HARDNESS	Rc 55 MIN	Rc 28 MIN		Rc 39 MIN PASSIVATED	TO P/N FOR 17-4PH
MATERIAL	AMS 5630 (440C)	AMS 5643 (17-4PH)	KARON SEE TABLE 2 FOR LINER OPTIONS	4340 OR 4230 ALLOY STEEL	ADD SUFFIX A
HARDNESS	Rc 55 MIN	Rc 28 MIN		Rc 39 MIN CAD. PLATED	TO P/N FOR ALLOY STEEL

NOTE 1: Load ratings shown are based on Karon B liner system

BEARING SIZE	No Load Rotational Breakaway Torque (N-m)
3 & 4	0.06 to 0.68
5 TO 12	0.11 to 1.69
14 TO 16	0.11 to 2.71

# KARON Lined Rod End Bearings

## KR-M Series – Rod End, Male Dimensionally Equivalent to Mil-B-81935/1

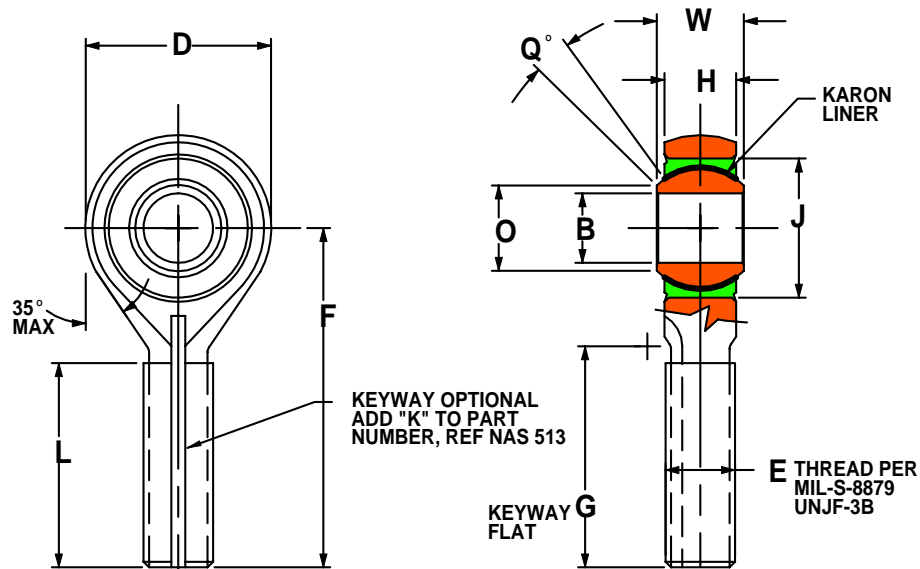

PART NUMBER EXAMPLE:

**KR 6-M S B L K**

- "K" FOR KEYWAY
- "L" FOR LEFT HAND THREAD
- KARON B LINER (SEE TABLE 2 FOR LINER OPTIONS)
- ROD END BODY MATERIAL, "S" OR "A"
- MALE ROD END BODY
- 9.525 mm DIA BORE, BORE SIZE IN 1/16 INCH INCREMENTS
- BASIC ROD END PART NUMBER PREFIX

**METRIC**  
All Dimensions in Millimeters

M81935/1 SIZE	B	D	L	E	F	W	H	O	G	Q°	J	LOAD RATINGS (KN) See Note 1			WEIGHT MAX (KG)
BEARING NUMBER	BORE DIA	ROD END DIA.	THREAD LENGTH MIN	THREAD SIZE	BODY LENGTH	BALL WIDTH	BODY WIDTH	MIN BALL FLAT	KEYWAY FLAT	MIN	MAX HOUSING ID	ULT. STATIC	FATIGUE	AXIAL PROOF	
	+0.000 -0.013	+0.254 -0.254							+0.000 -0.508						
KR3-M	4.826	20.472	24.587	5/16-24	39.675	11.100	8.560	7.620	24.892	15	15.875	10.5	6.5	4.4	0.036
KR4-M	6.350	20.472	24.587	5/16-24	39.675	11.100	8.560	7.620	24.892	15	15.875	21.6	10.6	4.4	0.038
KR5-M	7.938	22.860	30.150	5/16-24	47.625	11.100	8.306	9.144	32.258	14	17.463	31.9	13.4	4.9	0.046
KR6-M	9.525	26.035	30.150	3/8-24	49.225	12.700	10.566	11.836	31.369	8	20.638	38.0	15.9	7.4	0.073
KR7-M	11.113	29.210	32.537	7/16-20	53.975	14.275	11.481	13.640	35.611	10	23.017	53.4	21.4	8.2	0.096
KR8-M	12.700	33.960	37.287	1/2-20	61.925	15.875	13.081	15.418	40.361	9	25.400	86.7	36.7	9.1	0.147
KR10-M	15.875	38.735	39.675	5/8-18	66.675	19.050	14.656	18.974	42.748	12	30.163	97.4	40.8	10.8	0.218
KR12-M	19.050	45.085	42.850	3/4-16	73.025	22.225	16.256	21.463	45.923	13	34.925	130.3	51.6	12.5	0.305
KR14-M	22.225	51.435	50.800	7/8-14	85.725	22.225	19.431	25.273	53.873	6	41.275	153.5	58.3	14.8	0.435
KR16-M	25.400	70.485	59.512	1 1/4-12	104.775	34.925	25.781	32.233	62.586	12	53.975	357.2	135.2	19.3	1.232

	BALL	RACE	LINER	BODY	DESIGNATION
<b>MATERIAL</b>	AMS 5630 (440C)	AMS 5643 (17-4PH)	<b>KARON</b>	<b>AMS 5643</b> (17-4PH)	<b>ADD SUFFIX S</b>
<b>HARDNESS</b>	Rc 55 MIN	Rc 28 MIN	SEE TABLE 2 FOR LINER OPTIONS	Rc 39 MIN PASSIVATED	TO P/N FOR 17-4PH
<b>MATERIAL</b>	AMS 5630 (440C)	AMS 5643 (17-4PH)	<b>KARON</b>	4340 OR 4230 ALLOY STEEL	<b>ADD SUFFIX A</b>
<b>HARDNESS</b>	Rc 55 MIN	Rc 28 MIN	SEE TABLE 2 FOR LINER OPTIONS	Rc 39 MIN CAD. PLATED	TO P/N FOR ALLOY STEEL

BEARING SIZE	No Load Rotational Breakaway Torque (N-m)
3 & 4	0.06 to 0.68
5 TO 12	0.11 to 1.69
14 TO 16	0.11 to 2.71

**NOTE 1:** Load ratings shown are based on Karon B liner system

# KARON Lined Rod End Bearings

## KR-FS Series – Rod End, Female, Miniature

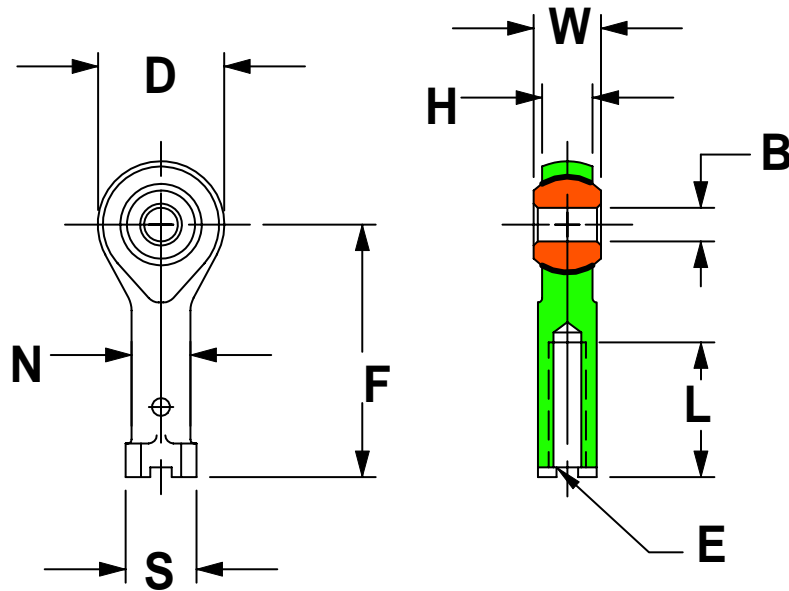

PART NUMBER EXAMPLE:

**KR 094 - FS B L K**

**KR** = BASIC KARON PART NUMBER PREFIX  
**094** = 2.388 mm ID (BORE SIZE IN 0.001 INCH INCREMENTS)

**FS** = MINIATURE FEMALE ROD END BODY  
**B** = KARON B LINER, SEE TABLE 2 FOR LINER OPTIONS

**L** = LEFT HAND THREAD OPTION

**K** = KEYWAY OPTION

**METRIC**

**All Dimensions in Millimeters**

KR( ) FS SERIES	B	D	L	E	F	N	W	H	S	ULT. STATIC LOAD (KN) SEE NOTES 1 & 2
BEARING NUMBER	BORE DIA +.000 -.013	ROD END DIA. +.254 -.254	THREAD LENGTH +.788 -.788	THREAD SIZE UNF-3B	BODY LENGTH +.254 -.254	SHANK DIA +.254 -.254	BALL WIDTH +.000 -.127	BODY WIDTH +.127 -.127	REF DIA OR DISTANCE ACROSS CORNERS	
KR047-FS	1.191	4.801	5.385	0-80	9.068	3.962	2.769	2.083	5.080	1.0
KR094-FS	2.383	6.350	6.604	3-56	12.471	4.750	3.175	2.134	5.842	1.8
KR125-FS	3.175	11.913	12.700	6-32	23.800	5.537	6.350	4.750	6.680	3.8
KR156-FS	3.962	14.275	15.875	8-32	28.575	6.350	7.137	5.563	7.493	4.7

	BALL	ROD END BODY	LINER
<b>MATERIAL</b>	AMS 5630 (440C)	AMS 5643 (17-4PH)	<b>KARON</b>
<b>HARDNESS</b>	Rc 55 MIN	Rc 28 MIN	SEE TABLE 2 FOR LINER OPTIONS

### NOTES

1. Load ratings shown are based on KARON B liner system
2. Loads shown are based on bearing components only, bolt/pin shear is not considered.
3. No load rotational breakaway torque = 0.11N-m maximum

## KARON Lined Rod End Bearings

## **KR-MS Series – Rod End, Male, Miniature**

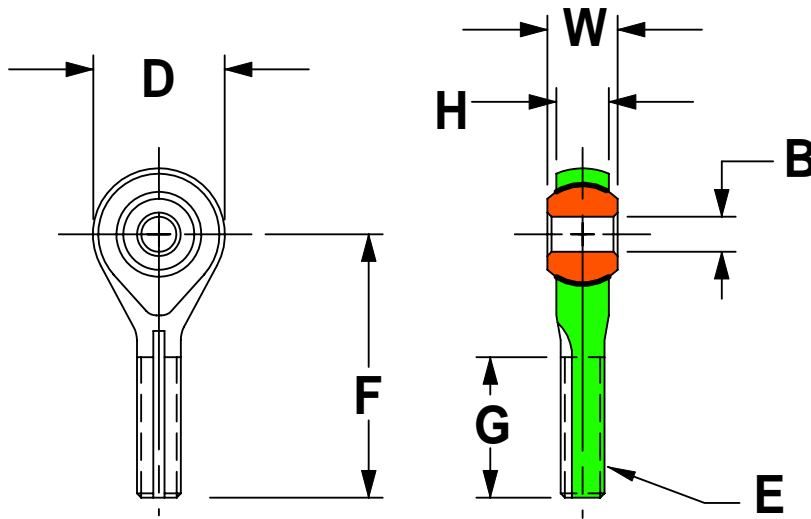

PART NUMBER EXAMPLE:

**KR 094 - MS B L K**

**KR** = BASIC KARON PART NUMBER PREFIX  
**094** = 2.388 mm ID (BORE SIZE IN 0.001 INCH INCREMENTS)  
**MS** = MINIATURE MALE ROD END BODY  
**B** = KARON B LINER, SEE TABLE 2 FOR LINER OPTIONS  
**L** = LEFT HAND THREAD OPTION  
**K** = KEYWAY OPTION

### **METRIC**

**All Dimensions in Millimeters**

KR( ) FM SERIES	B	D	G	E	F	W	H	ULT. STATIC LOAD (KN) SEE NOTES 1 & 2
BEARING NUMBER	BORE DIA +.000 -.013	ROD END DIA. +.254 -.254	THREAD LENGTH +.788 -.788	THREAD SIZE UNF-3A	BODY LENGTH +.254 -.254	BALL WIDTH +.000 -.127	BODY WIDTH +.127 -.127	
<b>KR047-MS</b>	1.191	4.801	5.385	0-80	9.068	2.769	2.083	1.0
<b>KR094-MS</b>	2.383	6.350	6.604	3-56	12.471	3.175	2.134	1.8
<b>KR125-MS</b>	3.175	11.913	12.700	6-32	23.800	6.350	4.750	3.8
<b>KR156-MS</b>	3.962	14.275	15.875	8-32	28.575	7.137	5.563	4.7

	BALL	ROD END BODY	LINER
<b>MATERIAL</b>	AMS 5630 (440C)	AMS 5643 (17-4PH)	<b>KARON</b>
<b>HARDNESS</b>	Rc 55 MIN	Rc 28 MIN	SEE TABLE 2 FOR LINER OPTIONS

### **NOTES**

1. Load ratings shown are based on KAron B liner system.
2. Loads shown are based on bearing components only, bolt/pin shear is not considered.
3. No load rotational breakaway torque = 0.11 N-m maximum

# KARON Lined Journal Bearings

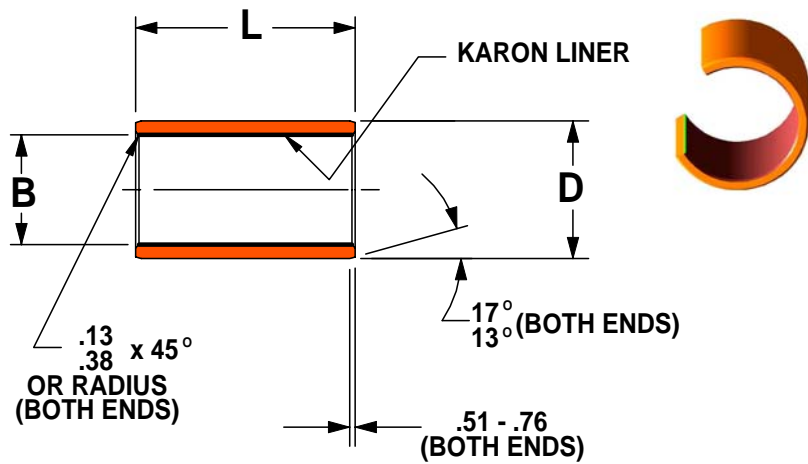

# KRJ-Series – Sleeve, Non-Flanged, Lined Bore

Qualified to SAE AS81934/1 with Karon B and Mil-B-8943 with Karon V, M, and RP

BEARING MATERIALS				
	MATERIAL	CONDITION	SURFACE FINISH	P/N SYMBOL
OUTER HOUSING	AMS 5643 17-4PH CRES	H1150	PASSIVATE PER QQ-P-35 OR CAD PLATE PER QQ-P-416	S
	QQ-A-200/3 OR QQ-A-225/8 2024 ALUMINUM	T851/T8511	ANODIZE PER MIL-A- 8625 TYPE I OR 11 OR CHEM FILM PER MIL-C-5541	Y
LINER	KARON	N/A	N/A	SEE TABLE 2 FOR LINER OPTIONS

## METRIC - All Dimensions in Millimeters

M81934/1 BEARING NUMBER	B BORE DIA + .000 - .0254	D OUTER DIA. See NOTE 1	T .254 O'SIZE DIA D See NOTE 1	U .508 O'SIZE DIA D See NOTE 1	L Mil Spec Length Limits (Suggested)		WEIGHT LBS/INCH (REF)	
					MIN	MAX	AL	CRES
					KRJ4	6.388	9.550	9.804
KRJ5	7.976	11.140	11.349	11.603	008	018	.008	.022
KRJ6	9.563	12.730	12.984	13.238	008	022	.009	.025
KRJ7	11.151	14.321	14.575	14.829	008	028	.010	.028
KRJ8	12.738	15.913	16.167	16.421	008	028	.011	.031
KRJ9	14.326	17.506	17.760	18.014	008	036	.013	.036
KRJ10	15.913	20.681	20.935	21.189	008	044	.022	.061
KRJ11	17.501	22.268	22.522	22.776	008	052	.023	.064
KRJ12	19.088	23.858	24.112	24.366	008	052	.025	.070
KRJ14	22.263	27.038	27.292	27.546	008	052	.029	.080
KRJ16	25.438	30.221	30.475	30.729	008	060	.033	.091
KRJ18	28.613	33.396	33.650	33.904	010	060	.037	.101
KRJ20	31.788	36.571	36.825	37.079	012	068	.040	.111
KRJ22	34.963	39.746	40.000	40.254	012	068	.044	.122
KRJ24	38.138	44.508	44.762	45.016	012	088	.065	.179
KRJ26	41.313	47.683	47.937	48.191	016	096	.070	.193
KRJ28	44.488	50.858	51.112	51.366	016	096	.075	.207
KRJ32	50.838	57.208	57.462	57.716	016	096	.085	.234

LENGTH SUFFIX			
CODE	LENGTH +.000 -.254	CODE	LENGTH +.000 -.254
-008	6.350	-048	38.100
-009	7.137	-050	39.675
-010	7.925	-052	41.275
-011	8.738	-054	42.850
-012	9.525	-056	44.450
-014	11.100	-058	46.025
-016	12.700	-060	47.625
-018	14.275	-062	49.200
-020	15.875	-064	50.800
-022	17.450	-066	52.375
-024	19.050	-068	53.975
-026	20.625	-070	55.550
-028	22.225	-072	57.150
-030	23.800	-074	58.725
-032	25.400	-076	60.325
-034	26.975	-078	61.900
-036	28.575	-080	63.500
-038	30.150	-082	65.075
-040	31.750	-084	66.675
-042	33.325	-086	68.250
-044	34.925	-088	69.850
-046	36.500	-096	76.200

PART NUMBER EXAMPLE:

**KRJ 8 - S B C - 032 - L I** (ADD "T" FOR .254 OR "U" FOR .508 OVERSIZE DIA "D")

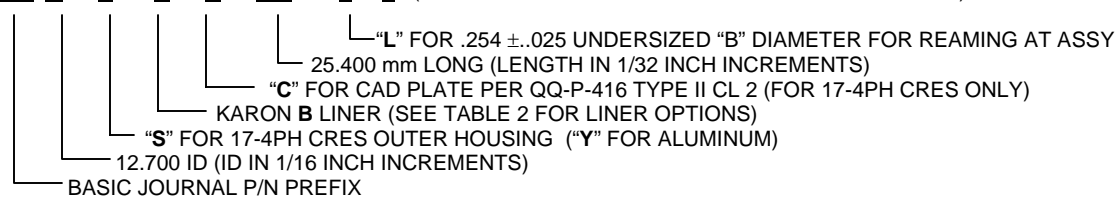

**NOTE 1:**  
TOLERANCE, 17-4PH = +.000, -.013  
ALUMINUM, ± .013

# KARON Lined Journal Bearings

## KRJ-U (D) Series – Sleeve, Flanged, Lined Bore, (Optional Lined Flange)

Qualified to SAE AS81934/2 with Karon B and Mil-B-8943 with Karon V, M, and RP

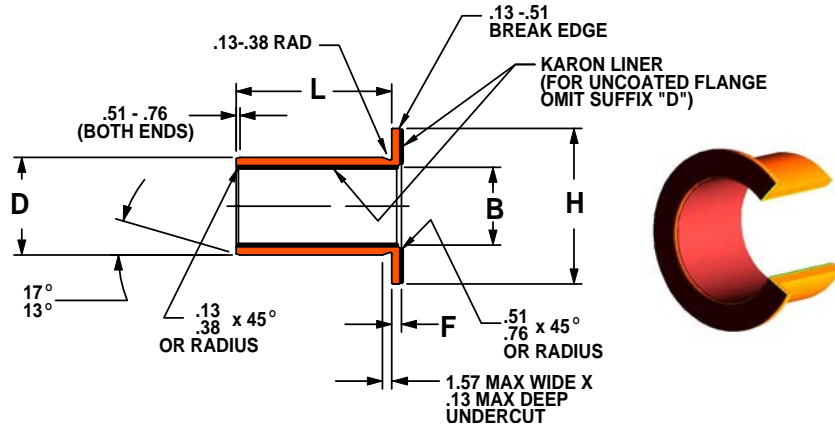

BEARING MATERIALS				
	MATERIAL	CONDITION	SURFACE FINISH	P/N SYMBOL
OUTER HOUSING	AMS 5643 17-4PH CRES	H1150	PASSIVATE PER QQ-P-35 OR CAD PLATE PER QQ-P-416	S
	QQ-A-200/3 OR QQ-A-225/8 2024 ALUMINUM	T851/T8511	ANODIZE PER MIL-A- 8625 TYPE I OR 11 OR CHEM FILM PER MIL-C-5541	Y
LINER	KARON	N/A	N/A	SEE TABLE 2 FOR LINER OPTIONS

### METRIC - All Dimensions in Millimeters

M81934/2	B	D	H	F	T .254 O'SIZE DIA D	U .508 O'SIZE DIA D	L Mil Spec Length Limits (Suggested)		FLANGE WEIGHT LBS/INCH (REF) NOTE 2	
BEARING NUMBER	BORE DIA + .000 - .0254	OUTER DIA. See NOTE 1	FLANGE DIA + .000 - .508	FLANGE WIDTH + .000 - .127	See NOTE 1	See NOTE 1	MIN	MAX	AL	CRES
KRJ4-UD	6.388	9.550	19.050		9.804	10.058	.008	.014	.003	.007
KRJ5-UD	7.976	11.140	20.625		11.349	11.603	.008	.018	.003	.007
KRJ6-UD	9.563	12.730	22.225		12.984	13.238	.008	.022	.003	.007
KRJ7-UD	11.151	14.321	23.800		14.575	14.829	.008	.028	.013	.008
KRJ8-UD	12.738	15.913	25.400		16.167	16.421	.008	.028	.004	.010
KRJ9-UD	14.326	17.506	28.575	1.588	17.760	18.014	.008	.036	.004	.011
KRJ10-UD	15.913	20.681	31.750		20.935	21.189	.008	.044	.005	.014
KRJ11-UD	17.501	22.268	34.925		22.522	22.776	.008	.052	.007	.020
KRJ12-UD	19.088	23.858	38.100		24.112	24.366	.008	.052	.009	.023
KRJ14-UD	22.263	27.038	41.275		27.292	27.546	.008	.052	.009	.025
KRJ16-UD	25.438	30.221	44.450		30.475	30.729	.008	.060	.010	.027
KRJ18-UD	28.613	33.396	47.625		33.650	33.904	.010	.060	.014	.041
KRJ20-UD	31.788	36.571	50.800		36.825	37.079	.012	.068	.018	.050
KRJ22-UD	34.963	39.746	53.975		40.000	40.254	.012	.068	.019	.053
KRJ24-UD	38.138	44.508	57.150	2.380	44.762	45.016	.012	.088	.019	.054
KRJ26-UD	41.313	47.683	60.325		47.937	48.191	.016	.096	.020	.056
KRJ28-UD	44.488	50.858	63.500		51.112	51.366	.016	.096	.023	.064
KRJ32-UD	50.838	57.208	69.850		57.462	57.716	.016	.096	.026	.072

LENGTH SUFFIX			
CODE	LENGTH + .000 - .254	CODE	LENGTH + .000 - .254
-008	6.350	-048	38.100
-009	7.137	-050	39.675
-010	7.925	-052	41.275
-011	8.738	-054	42.850
-012	9.525	-056	44.450
-014	11.100	-058	46.025
-016	12.700	-060	47.625
-018	14.275	-062	49.200
-020	15.875	-064	50.800
-022	17.450	-066	52.375
-024	19.050	-068	53.975
-026	20.625	-070	55.550
-028	22.225	-072	57.150
-030	23.800	-074	58.725
-032	25.400	-076	60.325
-034	26.975	-078	61.900
-036	28.575	-080	63.500
-038	30.150	-082	65.075
-040	31.750	-084	66.675
-042	33.325	-086	68.250
-044	34.925	-088	69.850
-046	36.500	-096	76.200

PART NUMBER EXAMPLE:

**KRJ 8 - U D S B C - 032 - L I** ( ADD "T" FOR .254 OR "U" FOR .508 OVERSIZE DIA "D" )

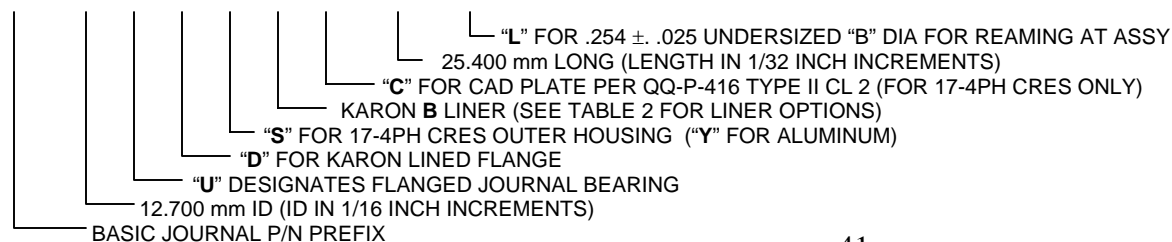

#### NOTES:

- TOLERANCE, 17-4PH = +.000, -.013  
ALUMINUM, ± .013
- ADD FLANGE WEIGHT TO THE SLEEVE  
WEIGHT SHOWN FOR THE EQUIVALENT  
DIAMETER "KRJ" NON-FLANGED BEARING



